



WOODWORKING



Get a grip
– quick, easy and precise



Product Catalogue
Chucks/Arbors



**Innovation
for your
efficiency**

ETP Transmission AB has developed and manufactured hydraulic chucks and arbors for more than 40 years under the brand name ETP HYDRO-GRIP for the woodworking industry.

We are a global company and our customers are the leaders within their respective segments. This is the way we like it, working with people that demand the absolute best from us means we are constantly developing and improving ourselves and our products. It is your challenges that drive us forward.

This catalogue covers our standard products for the woodworking industry and in addition to this we also manufacture customized designed products for all types of wood machining.

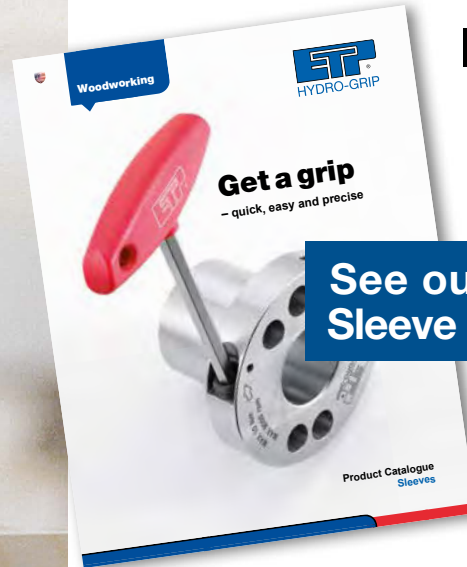

**In need of
hydraulic
sleeves?**

**See our separate
Sleeve Catalogue!**



Quick, easy and precise

It takes just a few seconds to get perfect centering and fastening of your tools when attached to an ETP HYDRO-GRIP. The extremely high precision achieved by using ETP HYDRO-GRIP results in minimal runout, unrivalled repeatability and the best possible surface finish at super high feed speeds.

Our customers and worldwide users can confirm what this means in terms of dramatically improved cost-effectiveness.



ETP Transmission Inc

1169 Tower Rd, Schaumburg, IL 60173. US

Phone: +1 630-237-4386

E-mail: sales@etpinc.com, Internet: www.etp.se



Table of contents Page

Hydraulic chucks

COMPACT HSK63F & E	6
COMPACT SK30	7
SLENDER HSK63F	8
SLENDER SK30	9
COMBO HSK63F	10
PENCIL HSK63F	11
ER PLUG & PLAY 	12-13

Hydraulic arbors

GEW2 PowerLock	15
GE2 HSK 63F	16
GE2 HSK 63 F mod.	17

Accessories

Reduction sleeves	18-19
Extractors	19
Torque wrenches	19

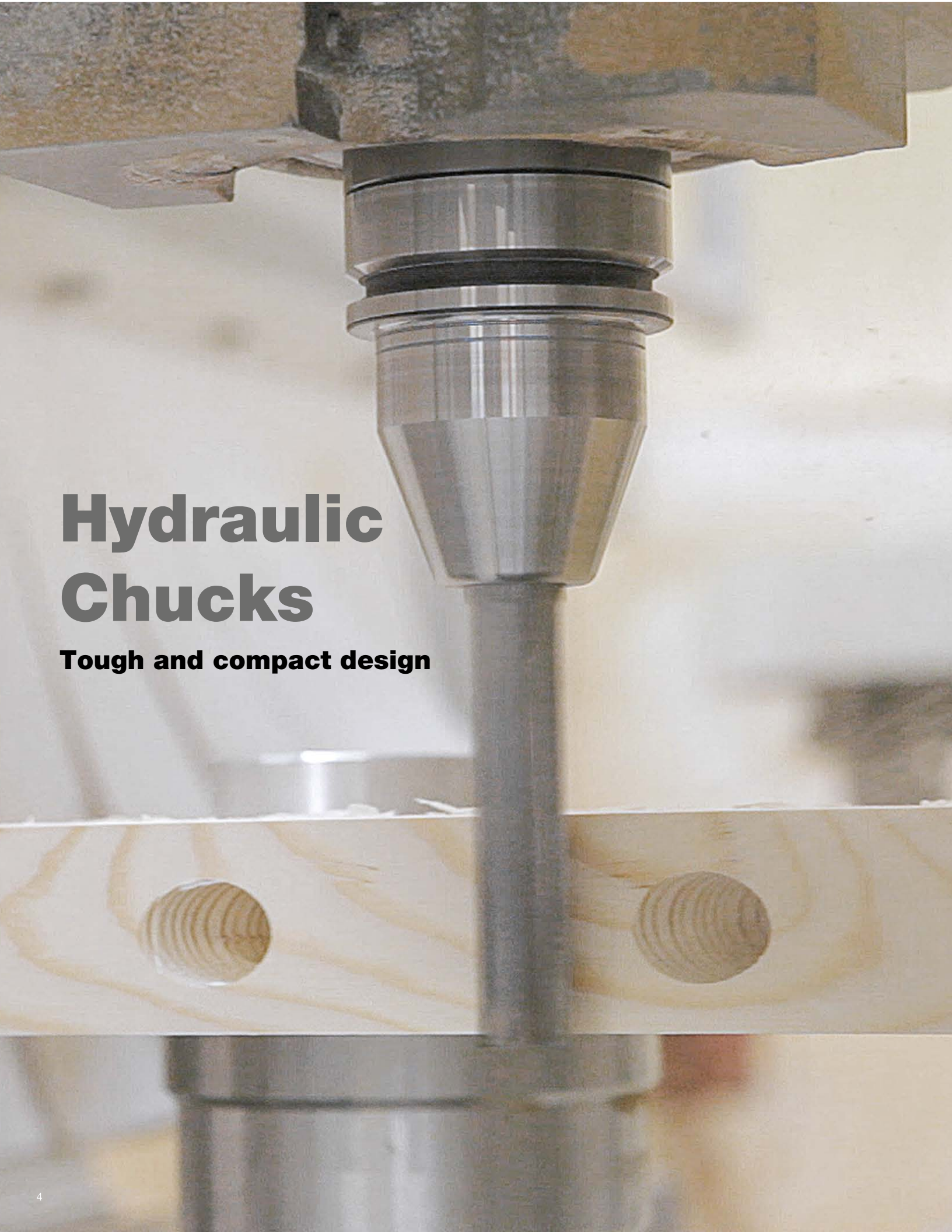

Hydraulic Chucks

Tough and compact design

ETP HYDRO-GRIP® COMPACT

Hydraulic high precision toolholder



The short design of 75 mm makes ETP HYDRO-GRIP COMPACT your ideal replacement for any ER collet holder.

Allowing more and more users to fully benefit from all the positives of hydraulic clamping such as easy

handling and decreased tool wear. ETP HYDRO-GRIP COMPACT has a very compact and robust design. Tools changes are made quickly, easily and with a high level of precision.

The high clamping force guarantees a secure clamping of your cutting tools.

With a minimum tool runout a good surface finish is achieved along with an extended tool life. ETP HYDRO-GRIP COMPACT can be used with reduction sleeves for maximum flexibility.

Benefits & Features

- Short overhang
- Easy handling
- High clamping force
- Can be used with reduction sleeves



Easy mounting with torque wrench



Vibration damping



High runout accuracy



Fast set-up time

ETP HYDRO-GRIP® COMPACT HSK Form E & F - DIN 69893

Information:

- Runout accuracy ≤ 0.004 mm at $2.5 \times d1$ (max. 50 mm)
 ≤ 0.00016 inch at $2.5 \times d1$ (max. 1.969 inch)
- Tool shank h6 or h7 can be used
- Center thread, M8x1.25.
Axial length adjustment screw - included in shipment.
Max. adjustment 5 mm.
Part no: S502
- Coolant through on all holders.
Axial length adjustment screw with coolant hole -
available as accessory. Max. adjustment 5 mm.
To be ordered separately: Part no: S-7471

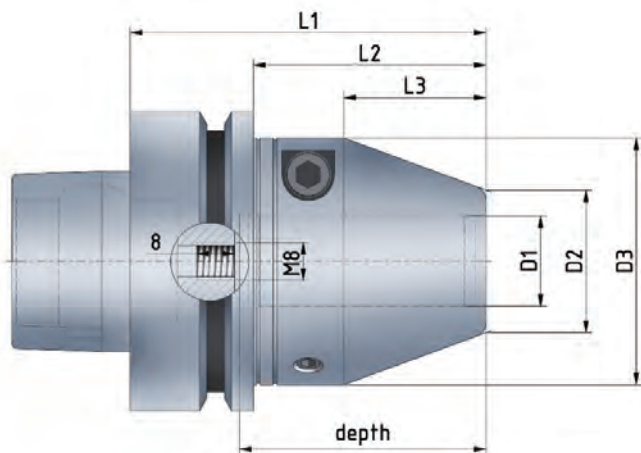

**Short
design
75 mm**



Metric range

Technical specification HSK form E & F

HSK size	Part no.	Item description	Dimensions, mm									
			D1	D2	D3	L1	L2	L3	depth	T* Nm	Weight kg	G 2.5 at rpm
● 63	705787	HG COMPACT-20/HSK63E	20	30	52	75	49	30	52	260 - 425	1.2	25 000
● 63	705788	HG COMPACT-25/HSK63E	25	35	59	75	49	9	56	480 - 710	1.4	25 000
● 63	705762	HG COMPACT--12/HSK63F	12	22	43.5	75	49	18	40	60 - 125	1.1	25 000
● 63	705764	HG COMPACT--16/HSK63F	16	26	48	75	49	28	50	165 - 270	1.1	25 000
● 63	705766	HG COMPACT--20/HSK63F	20	30	52	75	49	30	52	260 - 425	1.1	25 000
● 63	706274	HG COMPACT--25/HSK63F	25	35	59	75	49	9	56	480 - 710	1.3	25 000

Inch range

Technical specification HSK form E & F

HSK size	Part no.	Item description	Dimensions, inch									
			D1	D2	D3	L1	L2	L3	depth	T* ft·lb	Weight kg	G 2.5 at rpm
● 63	706258	HG COMPACT-3/4"/HSK63E	0.750	1.181	2.047	2.953	1.929	1.181	2.047	192-314	1.2	25 000
● 63	706259	HG COMPACT-1"/HSK63E	1.000	1.378	2.323	2.953	1.929	0.354	2.205	354 - 524	1.4	25 000
● 63	705763	HG COMPACT-1/2"/HSK63F	0.500	0.866	1.713	2.953	1.929	0.709	1.575	55-105	1.1	25 000
● 63	705765	HG COMPACT--5/8"/HSK63F	0.625	1.024	1.890	2.953	1.929	1.102	1.969	122-199	1.1	25 000
● 63	705681	HG COMPACT--3/4"/HSK63F	0.750	1.181	2.047	2.953	1.929	1.181	2.047	192-314	1.1	25 000
● 63	706427	HG COMPACT-1"/HSK63F	1.000	1.378	2.323	2.953	1.929	0.354	2.205	354 - 524	1.3	25 000

- From stock
- On request

*) T_{min} = Minimum transmittable torque using a h6 cylindrical tool, full depth insert.

Accessories:

Use preset Torque Wrench to ensure correct mounting of tools.

6 Nm - Part no. 19050



ETP HYDRO-GRIP can be used with reduction sleeves.



ETP HYDRO-GRIP® COMPACT SK Form - 69871

Information:

- Runout accuracy ≤ 0.004 mm at $2.5 \times d1$ (max. 50 mm)
 ≤ 0.00016 inch at $2.5 \times d1$ (max. 1.969 inch)
- Tool shank h6 or h7 can be used
- Center thread, M8x1.25.
Axial length adjustment screw - included in shipment.
Max. adjustment 5 mm.
Part no: s502
- Coolant through on all holders.
Axial length adjustment screw with coolant hole -
available as accessory. Max. adjustment 5 mm.
To be ordered separately: Part no: S-7471

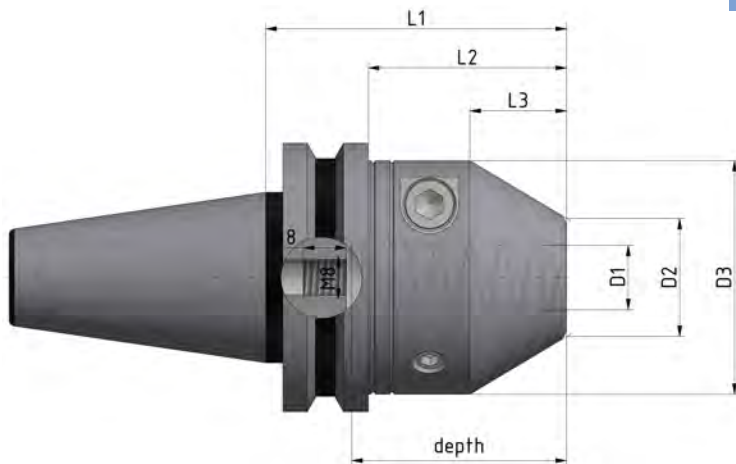

Metric range

Technical specification SK Form

SK size	Part no.	Item description	Dimensions, mm								T* Nm	Weight kg	G 2.5 at rpm
			D1	D2	D3	L1	L2	L3	depth				
● 30	706187	HG COMPACT-12/SK30	12	22	43.5	56	36.9	18	40	60 - 125	0.7	25 000	
● 30	706574	HG COMPACT-20/SK30	20	30	52	70	50.9	11	52	260 - 425	1.0	25 000	

Inch range

Technical specification SK Form

SK size	Part no.	Item description	Dimensions, inch								T* ft·lb	Weight kg	G 2.5 at rpm
			D1	D2	D3	L1	L2	L3	depth				
● 30	706573	HG COMPACT-1/2"/SK30	0.500	0.866	1.713	2.205	1.453	0.709	1.575	55-105	0.7	25 000	
● 30	706352	HG COMPACT-3/4"/SK30	0.750	1.181	2.047	2.756	2.004	0.433	2.047	192-314	1.0	25 000	

*) T_{min} = Minimum transmittable torque using a h6 cylindrical tool, full depth insert.

- From stock
- On request

Accessories:

Use preset Torque Wrench to ensure correct mounting of tools.
6 Nm - Part no. 19050



ETP HYDRO-GRIP can be used with reduction sleeves.





Slender design



Benefits and features

- Quick and easy tool change
- High performance
- Slender design
- Excellent runout

ETP HYDRO-GRIP® SLENDER HSK 63F

HYDRO-GRIP SLENDER is extremely user friendly which means quick and easy tool changes. It has a tough and compact design and it is the most slender chuck in our range. A safety feature prevents the tool from falling out when the chuck is not pressurized. The tool shank must be equipped with a thread corresponding to the safety screw size.

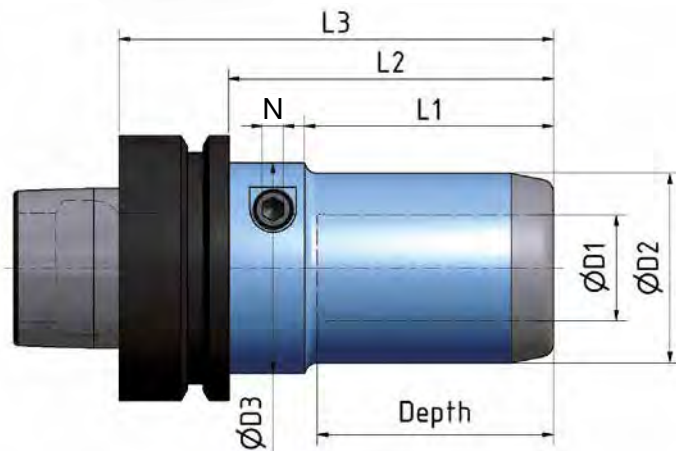

Technical specification ETP HYDRO-GRIP® SLENDER HSK 63F

Part.no	Item description.	...	Dimensions, mm							N	Max rpm
			D2	D3	L1	L2	L3	Depth*			
642680	SLENDER-12/HSK63F	12	32	40	43	61	87	40	5	25000	
642690	SLENDER-16/HSK63F	16	38	40	43	61	87	40	5	25000	
642700	SLENDER-20/HSK63F	20	40	50	55	73	99	52	5	25000	
639130	SLENDER-25/HSK63F	25	45	50	59	77	103	56	5	25000	
659400	SLENDER-3/8"/HSK63F	3/8"	32	40	43	61	87	40	5	25000	
642710	SLENDER-1/2"/HSK63F	1/2"	32	40	43	61	87	40	5	25000	
642720	SLENDER-5/8"/HSK63F	5/8"	38	40	43	61	87	40	5	25000	
642730	SLENDER-3/4"/HSK63F	3/4"	40	50	55	73	99	52	5	25000	
639140	SLENDER-1"/HSK63F	1"	45	50	59	77	103	56	5	25000	

TOLERANCES

The type SLENDER chuck is designed and manufactured for a router bit shank with the tolerance g6 (h7). Transmittable torque for tools with tolerances:

Type	h6	h7	g6	Safety screw
D	Nm	Nm	Nm	ISO 4762
12	60	30	30	M6x40
16	100	75	75	M6x40
20	260	175	175	M8x45
25	480	350	350	M8x45
3/8"	30	15	15	M6x40
1/2"	60	30	30	M6x40
5/8"	100	75	75	M6x40
3/4"	260	175	175	M8x45
1"	480	350	350	M8x45

*)= clamping length

- The runout is measured at 3xD and the max runout is ≤ 0,006 mm (0.00024 inch).
- The type SLENDER chuck is balanced to G2,5 at 25000 rpm.
- A normally balanced chuck and tool can be used up to a max. speed of 25000 rpm.
- Can be used with reduction sleeves, see page 15-16 for assortment.

- From stock
- On request



Slender design



Benefits and features

- Quick and easy tool change
- High performance
- Slender design
- Excellent runout

ETP HYDRO-GRIP® SLENDER SK30

HYDRO-GRIP type SLENDER is extremely user friendly which means quick and easy tool changes. It has a tough and compact design and it is the most slender chuck in our range. A safety feature prevents the tool from falling out when the chuck is not pressurized. The tool shank must be equipped with a thread corresponding to the safety screw size.

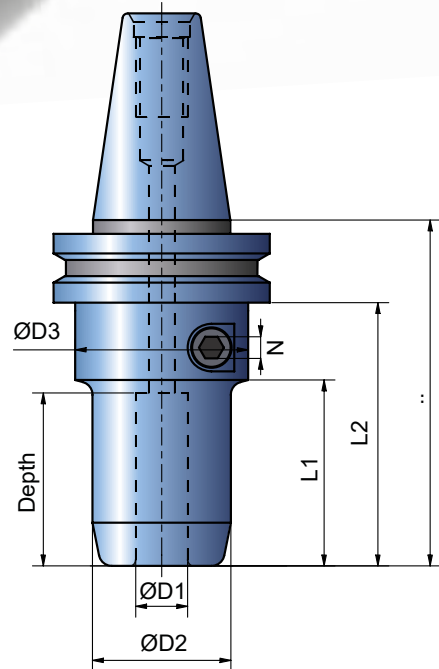

Technical specification ETP HYDRO-GRIP® SLENDER SK30

Dimensions, mm

Part.no	Item description	D1	D2	D3	L1	L2	L3	Depth*	N	Max rpm
701833	SLENDER-12/SK30	12	32	40	43	60,9	80	40	5	25000
702726	SLENDER-16/SK30	16	38	40	43	60,9	80	40	5	25000
702750	SLENDER-20/SK30	20	40	50	55	95,9	115	52	5	25000
701857	SLENDER-25/SK30	25	45	50	59	99,9	119	56	5	25000
702070	SLENDER-3/8"/SK30	3/8"	32	40	43	60,9	80	40	5	25000
702071	SLENDER-1/2"/SK30	1/2"	32	40	43	60,9	80	40	5	25000
702159	SLENDER-3/4"/SK30	3/4"	40	50	55	95,9	115	52	5	25000
703626	SLENDER-1"/SK30	1"	45	50	59	99,9	119	56	5	25000

TOLERANCES

The SLENDER chuck is designed and manufactured for a router bit shank with the tolerance g6 (h7). Transmittable torque for tools with tolerances:

Type	h6	h7	g6	Safety screw
D	Nm	Nm	Nm	ISO 4762
12	60	30	30	M6x40
16	100	75	75	M6x40
20	260	175	175	M8x45
25	480	350	350	M8x45
3/8"	30	15	15	M6x40
1/2"	60	30	30	M6x40
3/4"	260	175	175	M8x45
1"	480	350	350	M8x45

*)= clamping length

- The runout is measured at 3xD and the max runout is ≤ 0,006 mm (0.00024 inch).
- The type SLENDER chuck is balanced to G2,5 at 25000 rpm.
- A normally balanced chuck and tool can be used up to a max. speed of 25000 rpm.
- Can be used with reduction sleeves, see page 15-16 for assortment.

- From stock
- On request

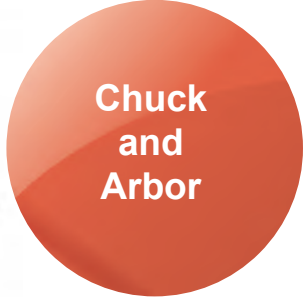

Benefits and features

- Quick, easy and independent tool change
- Multiple tool combination
- Optimized run time for each tool
- High performance and excellent run out

ETP HYDRO-GRIP® COMBO HSK 63F

The new COMBO let you enjoy all the benefits using a hydraulic chuck for your router bits and a hydraulic arbor for your profile tools at the same time. Perfectly centered and balanced.

Quick and easy tool changes independently for each tool, router bit vs. profile tool. The COMBO let you optimize your tool design for maximum performance and cost effectiveness.

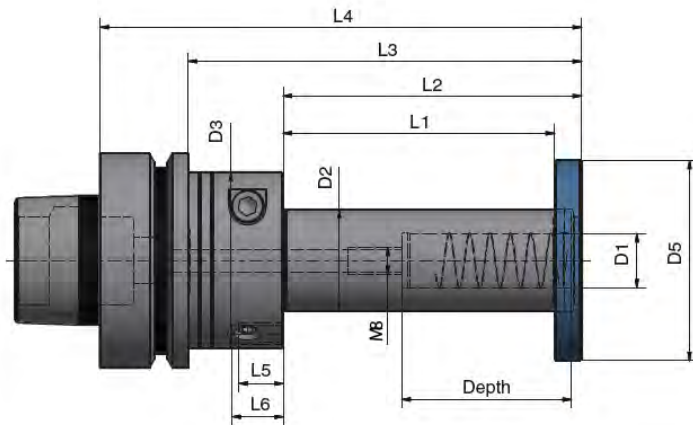
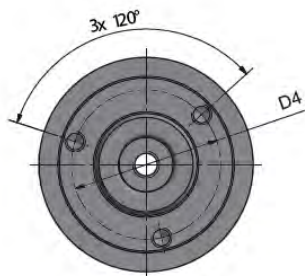

Technical Specification

HSK Size	Part no.	Item description	Dimensions, mm													Screw x3	Weight kg	G 2.5 at rpm
			D1	D2	D3	L1	L2	L3	L4	depth	D4	D5	L5	L6				
63	704991	COMBO-16/30x20 HSK63F	16	30	48	20	28	56	82	50	40	54	8	10	M6x35	1.2	12 000	
63	705806	COMBO-16/30x80 HSK63F	16	30	52	80	88	116	142	50	44	54	13	15	M6x100	1.6	12 000	
63	705832	COMBO-20/35x80 HSK63F	20	35	52	80	88	116	142	52	44	59	13	15	M6x100	1.8	12 000	
63 mod	705789	COMBO-16/30x20 HSK63F	16	30	48	20	28	56	82	50	40	54	8	10	M6x35	1.2	12 000	

HSK Size	Part no.	Item description	Dimensions, inch													Screw x3	Weight kg	G 2.5 at rpm
			D1	D2	D3	L1	L2	L3	L4	depth	D4	D5	L5	L6				
63	705825	COMBO-3/4"1 1/4"x80 HSK63F	0.750	1.250	2.047	3.150	3.465	4.567	5.591	1.969	1.732	2.323	0.512	0.591	M6x100	1.6	12 000	

- From stock
- On request

Router bit tool:
 Recommended tolerance - h7
 Runout accuracy ≤ 0.004 mm at 2.5 x D1 (max. 50 mm)
 ≤ 0.00016 inch at 2.5x D1 (max. 1.969 inch)
 ≤ 0.007 mm at 2.5 x D1 at length L4 > 125 mm
 ≤ 0.00028 inch at 2.5x D1 at length L4 > 4.921 inch
 Center thread, M8x1.25, for axial length adjustment screw (screw not included)

Profile tool:
 Recommended tolerance - H7
 Centering only.
 Security disc and 3 screws should always be mounted.
 Both Router bit and Profile tool has to be mounted before clamping.
 Security disc and 3 screws included in shipment.



Slim and long reach



Benefits and features

- For drilling to finishing
- Pencil design enabling machining in deep cavities and complex components
- High clamping force

ETP HYDRO-GRIP® PENCIL HSK 63F

ETP HYDRO-GRIP® PENCIL is with its extreme slim design one of the most versatile holder on the market. An extensive range of standard dimensions and lengths optimizes your productivity when machining deep cavities and complex components.

- Runout accuracy: ≤ 0.004 mm at 2.5 x dmt (max. 50 mm)
 ≤ 0.00016 inch at 2.5x dmt (max. 1.969 inch)
 ≤ 0.007 mm at 2.5 x dmt at length l1 > 125 mm
 ≤ 0.00028 inch at 2.5x dmt at length > 4.921 inch
- Balancing grade: G 2.5 at corresponding rpm - see in table below
- Tool shank h6 or h7 can be used
- Can be used with reduction sleeves, see page 15-16 for assortment

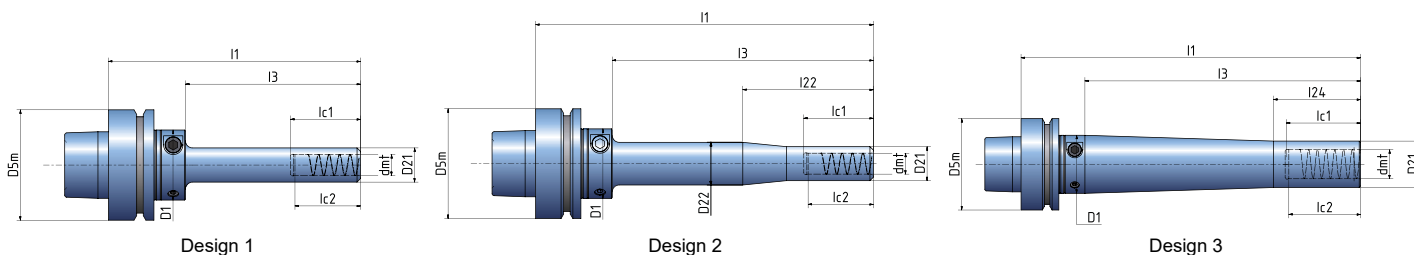

Technical specification ETP HYDRO-GRIP® PENCIL HSK 63F

Design	Part no.	Item description	Dimensions, mm											Max rpm		
			D _{5m}	d _{m1}	D ₁	D ₂₁	D ₂₂	l ₁	l ₃	l ₂₁	l ₂₂	l ₂₄	l _{c1}		l _{c2}	
●	1	684400	HG PENCIL-6x50/HSK63F	63	6	40	12		94	50				40	30	25 000
●	1	684440	HG PENCIL-12x50/HSK63F	63	12	40	19,5		94	50				40	37	25 000
●	1	684450	HG PENCIL-12x100/HSK63F	63	12	40	19,5		144	100				40	37	15 000
●	2	684460	HG PENCIL-12x150/HSK63F	63	12	40	19,5	24,5	194	150	50	75		40	37	10 000
●	3	684490	HG PENCIL-20x110/HSK63F	63	20	40	32		154	110			60	52	49	20 000
●	3	684500	HG PENCIL-20x190/HSK63F	63	20	40	32		234	190			60	52	49	10 000
●	1	684540	HG PENCIL-1/2"x50/HSK63F	63	12,7	40	19,5		94	50				40	37	25 000
●	1	684550	HG PENCIL-1/2"x100/HSK63F	63	12,7	40	19,5		144	100				40	37	15 000
●	2	684560	HG PENCIL-1/2"x150/HSK63F	63	12,7	40	19,5	24,5	194	150	50	75		40	37	10 000
●	3	684590	HG PENCIL-3/4"x110/HSK63F	63	19,05	40	32		154	110			60	52	49	20 000
●	3	684600	HG PENCIL-3/4"x190/HSK63F	63	19,05	40	32		234	190			60	52	49	10 000

- From stock
- On request

l₁ = programming length

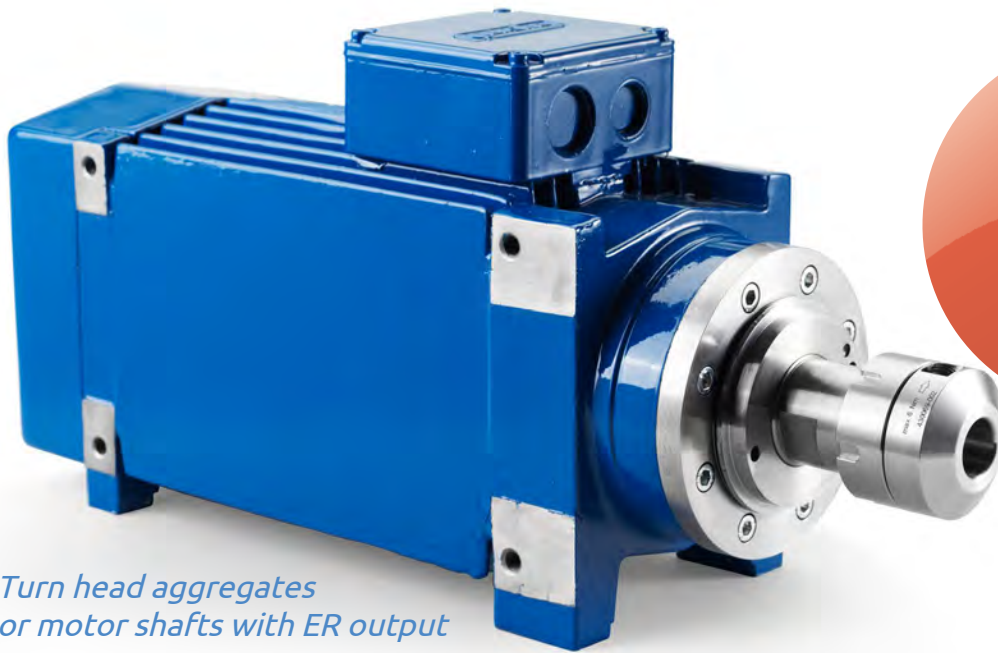

Turn head aggregates or motor shafts with ER output

BENEFITS & FEATURES

- Turn ER driven tools into hydraulic
- Easy handling and precision
- Excellent repeatability



NO MORE:

- Time-consuming tool changes
- Runout issues
- Limited clamping force

ETP HYDRO-GRIP® ER PLUG & PLAY



Upgrade your head aggregates with ETP hydraulic ER holder and enjoy multiple benefits

With ETP HYDRO-GRIP ER you can easily turn your standard ER collet driven tools into high precision hydraulic holders. Thus you can easily enjoy all the

positive benefits of hydraulic clamping such as easy handling and precision, at an impressive competitive price level. This enables more users to

benefit from decrease tool wear and increased productivity, when compared to using ER collet holders. Simply put it, just **Plug & Play!**

ETP HYDRO-GRIP® ER PLUG & PLAY

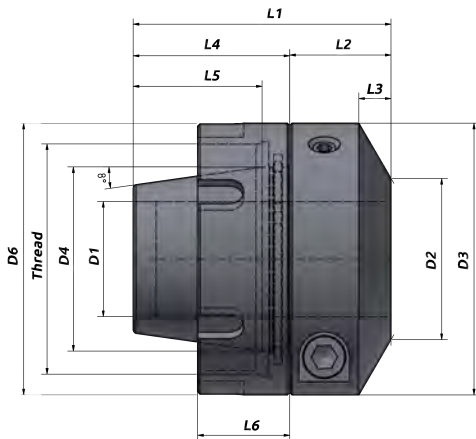

Metric range

Technical specification

ER size	Part no.	Item description	Dimensions, mm									Internal thread nut				Transmittable torque
			D1	D2	D3	D4	L1	L2	L3	L4	L5	D6	L6	Thread	Tt* Nm	T* Nm
25	671130	HYDRO-GRIP-12/ER25	12	26	40	25	40	13	7	27	21	40	17	M32x1.5	35	50-90
32	671150	HYDRO-GRIP-20/ER32	20	30	52	32	52	21.5	7	30.5	24.5	52	19	M40x1.5	40	230-370
40	671160	HYDRO-GRIP-25/ER40	25	35	59	40	56	22	7	34	28	59	20	M50x1.5	50	420-600

Inch range

Technical specification

ER size	Part no.	Item description	Dimensions, inch									Internal thread nut				Transmittable torque
			D1	D2	D3	D4	L1	L2	L3	L4	L5	D6	L6	Thread	Tt* Nm	T* ft-lb
25	671230	HYDRO-GRIP-1/2"/ER25	0.500	1.024	1.575	0.984	1.575	0.512	0.276	1.063	1.063	1.575	0.669	M32x1.5	35	37-66
32	671250	HYDRO-GRIP-3/4"/ER32	0.750	1.181	2.047	1.260	2.047	0.846	0.276	1.201	1.201	2.047	0.748	M40x1.5	40	170-273
40	671260	HYDRO-GRIP-1"/ER40	1.000	1.378	2.323	1.575	2.205	0.866	0.276	1.339	1.339	2.323	0.787	M50x1.5	50	310-443

*) T = Min. and Max transmittable torque using a h6 cylindrical tool, full depth insert. For additional information see section Technical Information.

**) Tt = Recommended tightening torque of the thread nut.

- From stock
- On request

Simple mounting procedure

1. Mount the ETP HYDRO-GRIP ER in the output shaft and twist to seal
2. Tighten the thread nut to the recommended tightening torque

VIEW VIDEO INSTRUCTION

Scan the code to see the complete procedure how to mount your ETP HYDRO-GRIP ER holder!

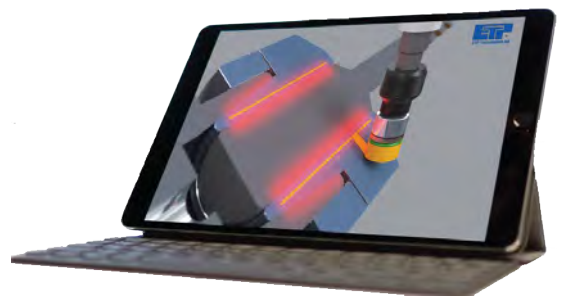

information:

- Runout accuracy < 0.02 mm.
- Tool shank h6 or h7 can be used.
- Balanced by design. Max. 25 000 rpm.

Accessories:

Use preset torque wrench, 6 Nm, to ensure correct mounting of tools.
Part no. 19050.

ETP HYDRO-GRIP ER can be used with reducing sleeves.





Hydraulic arbors



PowerLock Arbor



ETP HYDRO-GRIP® GEW2 PowerLock

HYDRO-GRIP GEW2 is our hydraulic precision arbor for the **PowerLock system**. This combination will give you all the benefits from both the hydraulic centering function and the PowerLock system. The GEW2 arbor expands uniformly and is the ultimate centering and fastening solution for your tools.

The pressurizing is carried out by using an allen T-wrench and the mechanism is well protected from dust behind a sealed plug. Furthermore the arbor has a thread and a locking nut that makes the tool assembly extremely quick and easy.

Benefits and features

- Multiple tool assembly
- Easy to pressurize with an allen T-wrench
- Sealed dust plug
- Ultimate centering and fastening

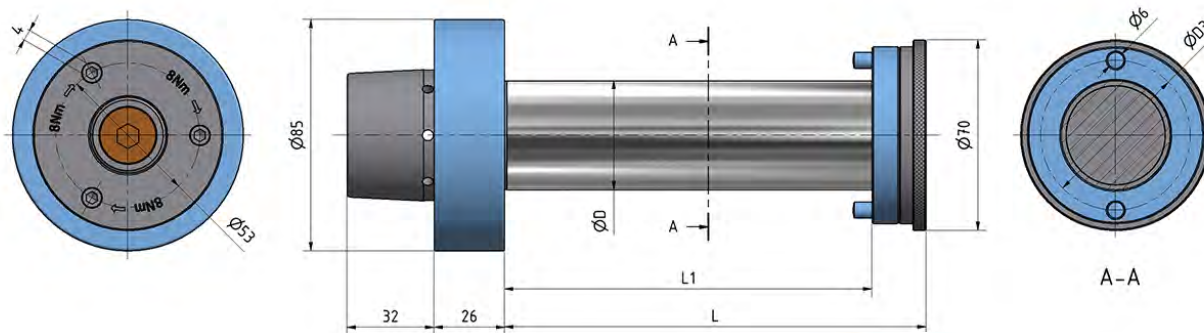

Technical specification ETP HYDRO-GRIP® GEW2

Part.no	Item description.	...	Dimensions, mm				
			D3	L1	L	N1	N2
665960-55	GEW2 30x55	30	55	55	75	5	5
665960-100	GEW2 30x100	30	55	100	120	5	5
655390	GEW2 40x55	40	55	55	75	5	5
704784	GEW2 40x80	40	55	80	100	8	8
655475	GEW2 40x135	40	55	135	155	8	8
665900-170	GEW2 40x170	40	55	170	190	8	8
655530	GEW2 40x240	40	55	240	260	8	8
666100-55	GEW2 50x55	50	62	55	75	8	8
666030-135	GEW2 50x135	50	62	135	155	8	8
666030-170	GEW2 50x170	50	62	170	190	8	8

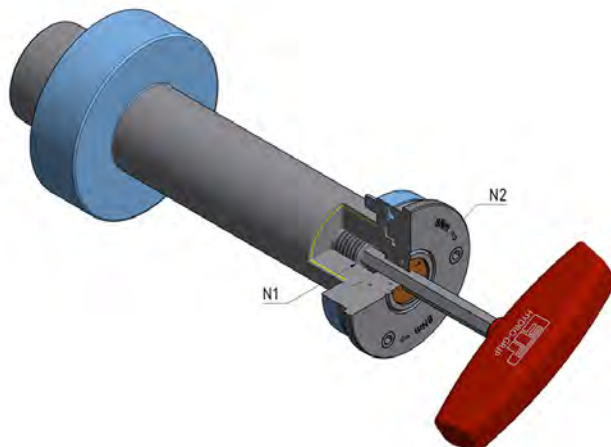

- From stock
- On request



Arbor

Benefits and features

- Quick and precise tool assembly.
- High performance and balance.
- Redesigned safety ring in light metal.
- Multiple tool attachment.
- Adapted for three wing tools.

ETP HYDRO-GRIP® GE2 HSK 63F

High performance units with perfect balance and runout for the tools. It can even be used in vertical mills, with or without tool changers.

The GE2 arbor allows quick and precise tool assembly and a high degree of flexibility. The arbor is adapted for easy attachment of three wing tools.

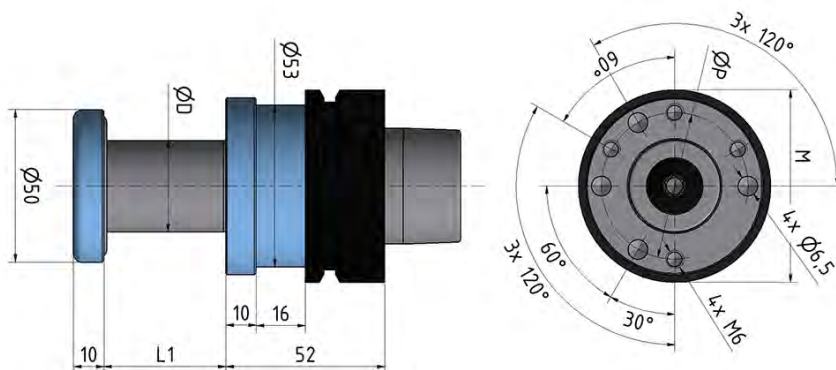

Technical specification ETP HYDRO-GRIP® GE2 HSK 63F

Part.no	Item description	D	L1	Dimensions, mm				N1	N2
				M	P	N1	N2		
● 667090	GE2-20x40/HSK 63F	20	40	53	32	6	8		
● 667020	GE2-25x55/HSK 63F	25	55	53	40	6	8		
● 666610	GE2-30x40/HSK 63F	30	40	58	48	6	8		
● 666650	GE2-30x55/HSK 63F	30	55	58	48	6	8		
● 666550	GE2-30x80/HSK 63F	30	80	58	48	6	8		
● 666340	GE2-30x100/HSK 63F	30	100	58	48	6	8		
● 704738	GE2-40x100/HSK 63F	40	100	67	56	6	8		
● 666710	GE2-1"x40/HSK 63F	1"	40	53	40	6	8		
● 666790	GE2-1"x55/HSK 63F	1"	55	53	40	6	8		
● 666840	GE2-1"x80/HSK 63F	1"	80	53	40	6	8		
● 666890	GE2-1 1/4"x40/HSK 63F	1 1/4"	40	58	48	6	8		
● 666970	GE2-1 1/4"x55/HSK 63F	1 1/4"	55	58	48	6	8		
● 667170	GE2-1 1/4"x100/HSK 63F	1 1/4"	100	63	48	6	8		

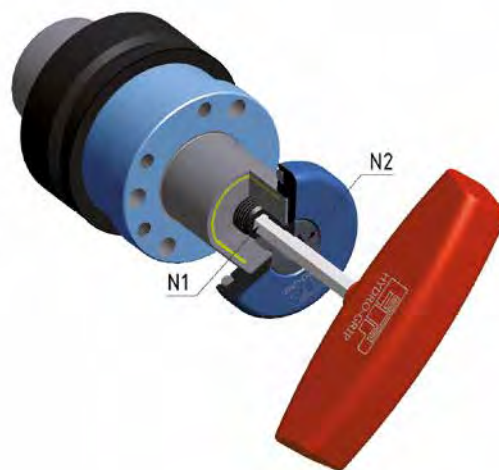

- From stock
- On request



Benefits and features

- Quick and precise tool assembly
- High performance and balance
- Easy interchange of tools between hydraulic- sleeves and arbors
- Combination with ETP CUBIT mini

ETP HYDRO-GRIP® GE2 HSK 63F mod.

This is the latest extension of our popular product line hydraulic arbors, designed for Homag through feed machines with HSK 63F modified motor spindle.

The new series include versions for single tools or tool sets with bore, and also units for adjustable tool sets. The later makes an excellent combination together with the adjustable unit, CUBIT mini.

The new products share the same benefits as all our hydraulic arbors, high performance due to excellent centering and balancing – the ultimate centering and fastening solution for your tools.

Existing tools or new tool sets can be switched between assembly on ETP HYDRO-GRIP type EI sleeves (used on machine spindles with hexagon) and the GE2 HSK 63F mod., which is suitable for flooring-, edge banding, double end tenoner machines.

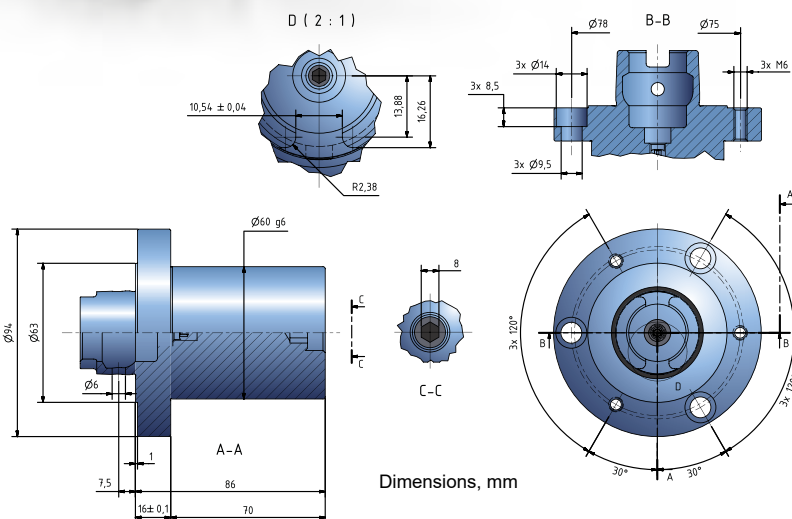

Technical specification

Part no.	Item description
662397	GE2-60x70/HSK63F mod.

The type GE2 HSK 63F mod. is designed for Homag through feed machines with HSK 63F modified motor spindle.

Recommended tool tolerance H7.

Pressurizing is carried out with an allen T-wrench, size 8 mm. Recommended tightening torque is 10 Nm.

- From stock
- On request

ACCESSORIES

Reduction Sleeves for ETP Toolholders

The reduction sleeves are designed to fit with the ETP Toolholders. They are specially suited for high precision clamping of cylindrical tool shanks.

Benefits and features

- **Accurate precision:**
High runout accuracy < 3 µm.
- **High flexibility:**
Clamping of different tool shank diameters. 12, 20, 25 and 1/2", 3/4", 1".
- **Power increase:**
When using reduction sleeves the transmittable torque is increased.



Outer-Ø of reduction sleeve corresponds to the type.
 HS12 = Ø 12 mm
 HS20 = Ø 20 mm
 HS25 = Ø 25 mm

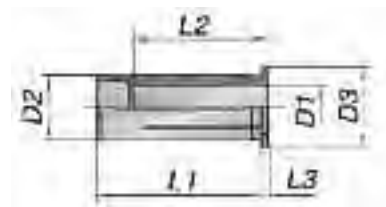

- From stock
- On request

Reduction sleeves mm to mm

Part no.	item description	D2 mm	D1 mm	D3 mm	L1 mm	L2 mm	L3 mm
Reduction Sleeves HS 6							
○ R1906.01000	HS 6 / 1 mm	6	1	9	27	20	3
○ R1906.02000	HS 6 / 2 mm	6	2	9	27	24	3
● R1906.03000	HS 6 / 3 mm	6	3	9	27	30	3
● R1906.04000	HS 6 / 4 mm	6	4	9	27	30	3
Reduction Sleeves HS 12-MB (Micro Bore)							
● R1912.01009	HS 12-MB / 1 mm	12	1.000	16	40	20	4
○ R1912.01509	HS 12-MB / 1,5 mm	12	1.500	16	40	20	4
○ R1912.02009	HS 12-MB / 2 mm	12	2.000	16	40	20	4
○ R1912.02509	HS 12-MB / 2,5 mm	12	2.500	16	40	20	4
Reduction Sleeves HS 12							
● R1912.03000	HS 12 / 3 mm	12	3.000	16	40	29	4
● R1912.04000	HS 12 / 4 mm	12	4.000	16	40	29	4
● R1912.05000	HS 12 / 5 mm	12	5.000	16	40	30	4
● R1912.06000	HS 12 / 6 mm	12	6.000	16	40	36	4
● R1912.07000	HS 12 / 7 mm	12	7.000	16	40	37	4
● R1912.08000	HS 12 / 8 mm	12	8.000	16	40	37	4
● R1912.09000	HS 12 / 9 mm	12	9.000	16	40	37	4
● R1912.10000	HS 12 / 10 mm	12	10.000	16	40	40	4

Reduction sleeves mm to mm

Part no.	item description	D2 mm	D1 mm	D3 mm	L1 mm	L2 mm	L3 mm
Reduction Sleeves HS 20							
● R1920.03000	HS 20 / 3 mm	20	3.000	25	50	28	4
● R1920.04000	HS 20 / 4 mm	20	4.000	25	50	28	4
● R1920.05000	HS 20 / 5 mm	20	5.000	25	50	28	4
● R1920.06000	HS 20 / 6 mm	20	6.000	25	50	36	4
● R1920.07000	HS 20 / 7 mm	20	7.000	25	50	38	4
● R1920.08000	HS 20 / 8 mm	20	8.000	25	50	37	4
● R1920.09000	HS 20 / 9 mm	20	9.000	25	50	38	4
● R1920.10000	HS 20 / 10 mm	20	10.000	25	50	40	4
● R1920.11000	HS 20 / 11 mm	20	11.000	25	50	40	4
● R1920.12000	HS 20 / 12 mm	20	12.000	25	50	45	4
● R1920.13000	HS 20 / 13 mm	20	13.000	25	50	45	4
● R1920.14000	HS 20 / 14 mm	20	14.000	25	50	45	4
● R1920.15000	HS 20 / 15 mm	20	15.000	25	50	45	4
● R1920.16000	HS 20 / 16 mm	20	16.000	25	50	48	4
● R1920.18000	HS 20 / 18 mm	20	18.000	25	50	48	4
Reduction Sleeves HS 25							
● R1925.03000	HS 25 / 3 mm	25	3.000	30	56	29	4
● R1925.04000	HS 25 / 4 mm	25	4.000	30	56	29	4
● R1925.05000	HS 25 / 5 mm	25	5.000	30	56	29	4
● R1925.06000	HS 25 / 6 mm	25	6.000	30	56	37	4
● R1925.07000	HS 25 / 7 mm	25	7.000	30	56	37	4
● R1925.08000	HS 25 / 8 mm	25	8.000	30	56	37	4
● R1925.09000	HS 25 / 9 mm	25	9.000	30	56	38	4
● R1925.10000	HS 25 / 10 mm	25	10.000	30	56	40	4
● R1925.12000	HS 25 / 12 mm	25	12.000	30	56	46	4
● R1925.14000	HS 25 / 14 mm	25	14.000	30	56	47	4
● R1925.16000	HS 25 / 16 mm	25	16.000	30	56	48	4
● R1925.18000	HS 25 / 18 mm	25	18.000	30	56	48	4
● R1925.20000	HS 25 / 20 mm	25	20.000	30	56	50	4

- Improper assembly can damage the concentricity of the reduction sleeve.
- Insert tools the full length of the reduction sleeve.
- Tool shank h6 or h7 can be used.
- Do not clamp reduction sleeve without a tool. Reduction Sleeve will be damaged.

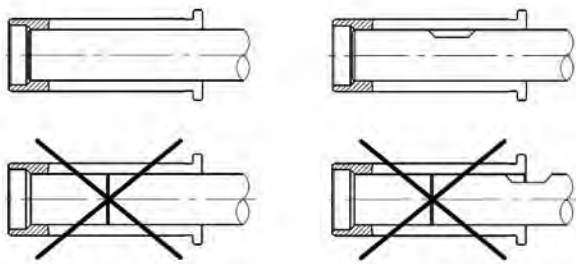

ACCESSORIES

Reduction sleeves inch to inch							
Part no.	item description	D2 inch	D1 inch	D3 inch	L1 inch	L2 inch	L3 inch
Reduction Sleeves HS 1/2"							
● R1913.03182	HS 1/2" / 1/8"	0.500	0.1250	0.630	1.575	1.142	0.157
● R1913.04762	HS 1/2" / 3/16"	0.500	0.1875	0.630	1.575	1.142	0.157
● R1913.06352	HS 1/2" / 1/4"	0.500	0.2500	0.630	1.575	1.417	0.157
● R1913.07942	HS 1/2" / 5/16"	0.500	0.3125	0.630	1.575	1.457	0.157
● R1913.09522	HS 1/2" / 3/8"	0.500	0.3750	0.630	1.575	1.575	0.157
Reduction Sleeves HS 3/4"							
● R1919.03182	HS 3/4" / 1/8"	0.750	0.1250	0.984	1.969	1.102	0.157
● R1919.04762	HS 3/4" / 3/16"	0.750	0.1875	0.984	1.969	1.102	0.157
● R1919.06352	HS 3/4" / 1/4"	0.750	0.2500	0.984	1.969	1.417	0.157
● R1919.07942	HS 3/4" / 5/16"	0.750	0.3125	0.984	1.969	1.457	0.157
● R1919.09522	HS 3/4" / 3/8"	0.750	0.3750	0.984	1.969	1.417	0.157
● R1919.11112	HS 3/4" / 7/16"	0.750	0.4375	0.984	1.969	1.575	0.157
● R1919.12702	HS 3/4" / 1/2"	0.750	0.5000	0.984	1.969	1.772	0.157
● R1919.14292	HS 3/4" / 9/16"	0.750	0.5625	0.984	1.969	1.772	0.157
● R1919.15882	HS 3/4" / 5/8"	0.750	0.6250	0.984	1.969	1.890	0.157
Reduction Sleeves HS 1"							
● R1926.03182	HS 1" / 1/8"	1.000	0.1250	1.181	2.205	1.142	0.157
○ R1926.04762	HS 1" / 3/16"	1.000	0.1875	1.181	2.205	1.142	0.157
● R1926.06352	HS 1" / 1/4"	1.000	0.2500	1.181	2.205	1.457	0.157
● R1926.07942	HS 1" / 5/16"	1.000	0.3125	1.181	2.205	1.457	0.157
● R1926.09522	HS 1" / 3/8"	1.000	0.3750	1.181	2.205	1.496	0.157
● R1926.11112	HS 1" / 7/16"	1.000	0.4375	1.181	2.205	1.575	0.157
● R1926.12702	HS 1" / 1/2"	1.000	0.5000	1.181	2.205	1.811	0.157
● R1926.14292	HS 1" / 9/16"	1.000	0.5625	1.181	2.205	1.850	0.157
● R1926.15882	HS 1" / 5/8"	1.000	0.6250	1.181	2.205	1.890	0.157
● R1926.17462	HS 1" / 11/16"	1.000	0.6875	1.181	2.205	1.890	0.157
● R1926.19052	HS 1" / 3/4"	1.000	0.7500	1.181	2.205	1.890	0.157

Reduction sleeves mm to inch							
Part no.	item description	D2 mm	D1 inch	D3 mm	L1 mm	L2 mm	L3 mm
Reduction Sleeves HS 12							
● R1912.03181	HS 12 / 1/8"	12	0.1250	16	40	29	4
● R1912.04761	HS 12 / 3/16"	12	0.1875	16	40	30	4
● R1912.06351	HS 12 / 1/4"	12	0.2500	16	40	36	4
● R1912.07941	HS 12 / 5/16"	12	0.3125	16	40	36	4
● R1912.09521	HS 12 / 3/8"	12	0.3750	16	40	37	4
Reduction Sleeves HS 20							
● R1920.03181	HS 20 / 1/8"	20	0.1250	25	50	28	4
● R1920.04761	HS 20 / 3/16"	20	0.1875	25	50	28	4
● R1920.06351	HS 20 / 1/4"	20	0.2500	25	50	36	4
● R1920.07941	HS 20 / 5/16"	20	0.3125	25	50	37	4
● R1920.09521	HS 20 / 3/8"	20	0.3750	25	50	36	4
● R1920.11111	HS 20 / 7/16"	20	0.4375	25	50	40	4
● R1920.12701	HS 20 / 1/2"	20	0.5000	25	50	45	4
● R1920.14291	HS 20 / 9/16"	20	0.5625	25	50	45	4
● R1920.15881	HS 20 / 5/8"	20	0.6250	25	50	48	4
Reduction Sleeves HS 25							
● R1925.03181	HS 25 / 1/8"	25	0.1250	30	56	29	4
● R1925.06351	HS 25 / 1/4"	25	0.2500	30	56	37	4
● R1925.07941	HS 25 / 5/16"	25	0.3125	30	56	37	4
● R1925.09521	HS 25 / 3/8"	25	0.3750	30	56	38	4
○ R1925.11111	HS 25 / 7/16"	25	0.4375	30	56	40	4
● R1925.12701	HS 25 / 1/2"	25	0.5000	30	56	46	4
● R1925.15881	HS 25 / 5/8"	25	0.6250	30	56	48	4
● R1925.17461	HS 25 / 11/16"	25	0.6875	30	56	48	4
● R1925.19051	HS 25 / 3/4"	25	0.7500	30	56	48	4

HYDRO-GRIP® Torque Wrench

Use torque wrench to ensure correct tightening independent on user. Should be used with all HYDRO-GRIP® holders.



Item description	Tightening torque:		Part no.
	nm	ft · lb	
● Torque wrench (5 mm Hex)	6	4.4	19050
● Torque wrench (5 mm Hex)	10	7.4	19052

Extractor

Item description	Part no.	For Sizes	A	B
			[mm]	[mm]
● EHS 12 - 1/2"	E7321.12000	HS 12	24.6	100
● EHS 20 - 3/4"	E7321.20000	HS 20	38.0	160
● EHS 25 - 1"	E7321.25000	HS 25	51.0	180

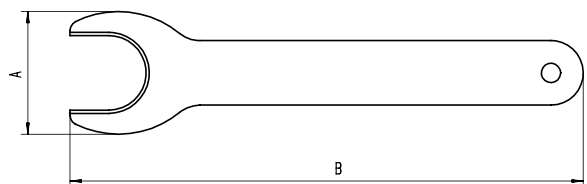

The extractor helps to remove the reduction sleeve from the toolholder.

- From stock
- On request



1169 Tower Rd, Schaumburg, IL 60173. US
Phone: +1 630-237-4386
E-mail: sales@etpinc.com, Internet: www.etp.se