



Hydraulic high precision toolholders



ETP HYDRO-GRIP

Hydraulic high precision toolholders

HYDRO-GRIP high precision tool holders are your guarantee of secure clamping for milling, drilling and reaming tools. Their unique strength provides precision and rigid-tool stability to improve machining performance for the largest number of applications. With the extensive range of HYDRO-GRIP® high precision toolholders all application areas, from finishing to heavy roughing, is covered. Bore diameters 6 – 32 mm available.

BENEFITS & FEATURES

- Easy handling and tool change
- Minimum tool run-out ensures good surface and extends tool life
- High speed capability
- Dampens noise and vibration
- Length pre-setting possible to save time

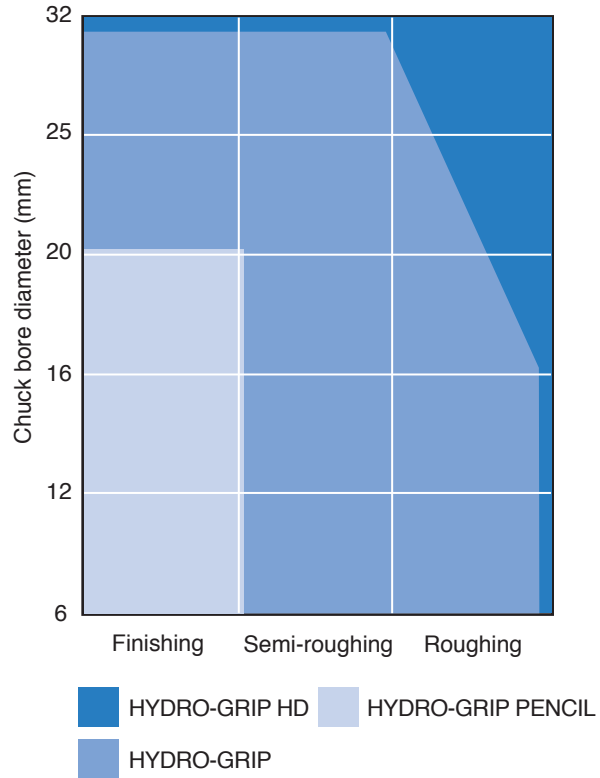

About ETP Transmission AB

ETP Transmission AB, after being in business for more than 40 years, has successfully developed products for 3 business or application areas.

- Metalworking • Woodworking
- Power Transmission under the registered trademarks ETP® and ETP HYDRO-GRIP®.

ETP Transmission AB

– leader in hydraulic clamping and centering products

Our business concept and all products are based upon the hydraulic principle. The ETP high precision products offer quick assembly and disassembly. With other words, you can fit your tools or components quick, easy and precise and run at high speeds. Within a few seconds you achieve perfect centering and fastening, simply by tightening of only one screw. Saving you time and money.

We are a global company and our customers are the leaders within their segments.

This is the way we like it, working with companies that expect the absolute best from us. Your challenges drive us forward!



Key to symbols



Easy mounting with torque wrench

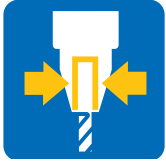

High clamping force



High runout accuracy



Vibration damping



Fast set-up time

Table of content

Page

The basic design	4
Product overview - ETP HYDRO-GRIP Family	5
Product overview - Assortment	6
Product overview - Area of application	7
Product overview - ETP HYDRO-GRIP Family	8-11
HSK	12-19
ISO	20-24
BT	25-30
CAT	31-37
PSK	38-42
Cylindrical extension	43
ECOGRIP ER - For outer threaded toolholders and driven tools	44
ECOGRIP ER - For inner threaded driven tools	45
<i>Accessories</i>	
– Reduction Sleeves	46-48
– Torque wrench and Extractor	49-51

Delivery times

- From stock
- On request

Industry segments

ETP HYDRO-GRIP has for many years enabled high quality machining within industry segment with high quality demands, such as: Aerospace, Automotive, Die & Mould, General Machining, Medical, Oil & Gas.



The basic design: ETP HYDRO-GRIP - Hydraulic high precision toolholder

Toolholder shank:

ETP HYDRO-GRIP is available in a large assortment of different machine interface shanks:

- PSK – C3, C4, C5, C6, C8
- HSK – 32, 40, 50, 63, 100
- ISO – 30, 40, 50
- BT – 30, 40, 50
- CAT – 40, 50

Pressure system:

Pressure screw and piston with sealing system.

- Optimised for thousands of pressure settings.
- Low tightening torque (6 or 10 Nm)
- Easy handling

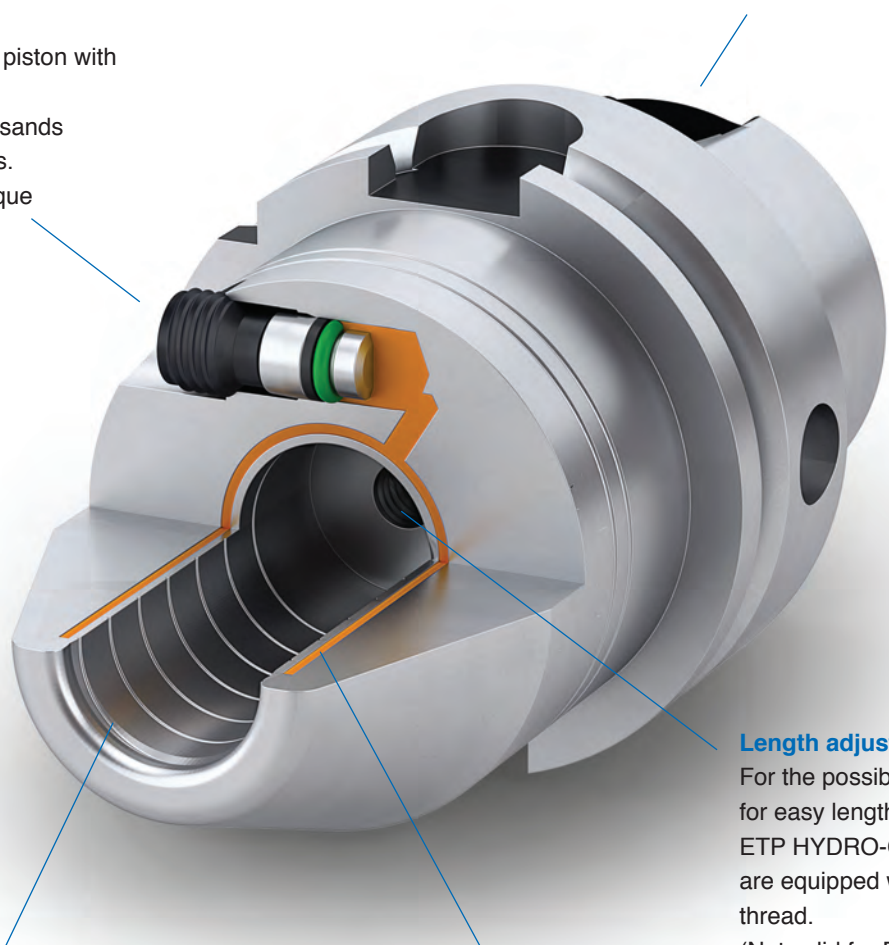

Length adjustment:

For the possibility to add screw for easy length adjustment ETP HYDRO-GRIP toolholders are equipped with a center thread.
(Not valid for PENCIL design).

The groove:

The integral spiral groove ensures any residual coolant on the tool to be removed from the contact surface when mounting the tool.

- Ensures high gripping force at any time

Pressure chamber:

- Secure clamping of any tool type.
A robust membrane and minimum amount of pressure media ensures a good temperature working range.

BENEFITS & FEATURES

- For drilling to semi-roughing
- High clamping force
- Easy handling
- Short overhang
- Modular design possibility

Product overview

ETP HYDRO-GRIP Family

ETP HYDRO-GRIP®
THE ORIGINAL



ETP HYDRO-GRIP® HD
HEAVY DUTY



ETP HYDRO-GRIP® G2 SLENDER
SLENDER DESIGN



ETP HYDRO-GRIP® PENCIL
SLIM AND LONG REACH



ETP HYDRO-GRIP® S
GRINDING HOLDER



ETP ECOGRIP®
ECONOMY LINE



ETP ECOGRIP® ER
ADJUSTABLE HOLDER



Product overview







Assortment

The ETP HYDRO-GRIP high precision toolholders offers you the most complete advantages of any hydraulic holder available on the market today. No other fastening technology than hydraulic clamping offers you the highest precision, in terms of tool life and higher surface quality, in combination with a total concept of easy handling and flexibility in design.

ETP combines easy handling and low maintenance with an extensive range!



Interfaces

Toolholder	HSK Page 12-19	ISO Page 20-24	BT Page 25-30	CAT Page 31-37	PSK Page 38-42	ER Page 44-45
 ETP HYDRO-GRIP	HSK 32C HSK 40C HSK 50C HSK 63A/C HSK 100A/C	ISO 30 ISO 40 ISO 50	BT 40 BT 50	CAT 40 CAT 50	PSK C3 PSK C4 PSK C5 PSK C6 PSK C8	
 ETP HYDRO-GRIP HD	HSK 63A/C HSK 100A/C	ISO 40 ISO 50	BT 40 BT 50	CAT 40 CAT 50	PSK C5 PSK C6 PSK C8	
 ETP HYDRO-GRIP G2 SLENDER	HSK 63F			CAT 40 CAT 50		
 ETP HYDRO-GRIP PENCIL	HSK 63A/C HSK 63F HSK 100A/C	ISO 40 ISO 50	BT 30 BT 40 BT 50	CAT 40 CAT 50	PSK C4 PSK C5 PSK C6 PSK C8	
 ETP HYDRO-GRIP S		ISO 50				
 ETP ECOGRIP		ISO 40	BT 40			
 ETP ECOGRIP ER						ER 16 ER 20 ER 25 ER 32 ER 40 ER 50

Product overview

Area of application

HYDRO-GRIP high precision toolholders are your guarantee of secure clamping for milling, drilling and reaming tools. Their unique strength provides precision and rigid-tool stability to improve machining performance for the largest number of applications. With the extensive range

of HYDRO-GRIP high precision toolholders all application areas, from finishing to heavy roughing, is covered. Our wide selection of toolholders ensures that you find the right solution for almost any machining application. Regardless if it's a high volume milling cutting operation, HYDRO-GRIP HD,

or when machining difficult deep contours within the mold making industry, HYDRO-GRIP PENCIL. And don't forget, all HYDRO-GRIP toolholders can be used with reduction sleeves, for maximum flexibility!

	 Finishing	 Semi-Roughing	 Roughing	 Slot Milling	 Plunging	 Contour Milling	 Trochoidal Milling	 Drilling	 Reaming: Through Hole	 Tapping: Blind Hole	 Threading: Through Hole
Toolholder	Finishing	Semi-Roughing	Roughing	Slot Milling	Plunging	Contour Milling	Trochoidal Milling	Drilling	Reaming	Tapping	Thread Milling
ETP HYDRO-GRIP 	●	●			●	●		●	●	●	●
ETP HYDRO-GRIP HD 	●	●	●	●	●	●	●	●	●	●	●
ETP HYDRO-GRIP G2 SLENDER 	●	●				●		●	●	●	●
ETP HYDRO-GRIP PENCIL 	●				●	●		●	●		
ETP ECOGRIP 	●	●			●	●		●	●	●	●
ETP ECOGRIP ER 	●	●			●			●	●		



ETP HYDRO-GRIP®

ETP HYDRO-GRIP® has a very compact and robust design. Tools changes are made quickly, easily and with a high level of precision. The high clamping force guarantees a secure clamping of your milling, drilling and reaming tools. With a minimum tool runout a good

surface finish is achieved along with an extended tool life. In addition to our extensive standard range, ETP HYDRO-GRIP® can be made to your specific gauge line requirement, using our modular design possibility.

Hydraulic high precision toolholders



BENEFITS & FEATURES

- For drilling to semi-roughing
- High clamping force
- Easy handling
- Short overhang
- Modular design possibility



ETP HYDRO-GRIP® HD

ETP HYDRO-GRIP® HD, Heavy Duty, is the first hydraulic Power chuck available on the market. Here ETP combine all the positive benefits of hydraulic clamping, such as easy handling and precision, with an extreme high tool clamping force

capability and rigid design. A high bending stiffness and the dampening properties of the hydraulic pressure media makes ETP HYDRO-GRIP® HD the ideal holder for any machining, from heavy rough milling to finishing.

Heavy Duty version. Up to 1670 Nm holding torque!



BENEFITS & FEATURES

- For rough milling to finishing
- Extreme high clamping force
- Easy handling
- Rigid design

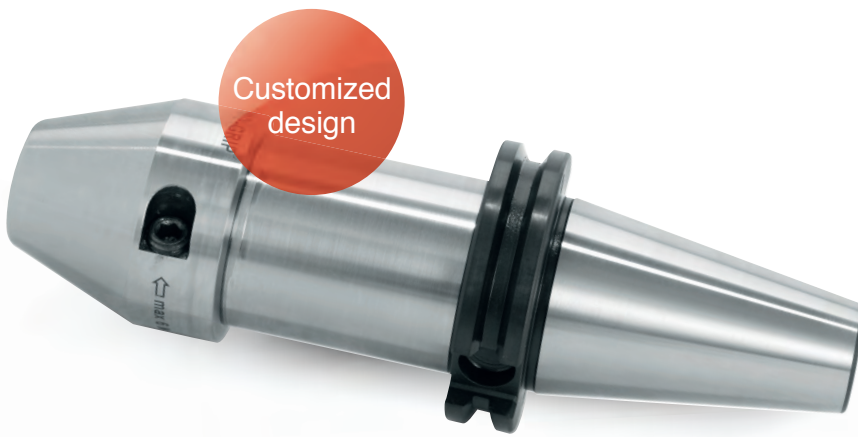

Customized design

ETP HYDRO-GRIP® CUSTOMIZED DESIGN

ETP HYDRO-GRIP toolholders can be made to your specific gauge line length requirement, using our modular design possibility.

Combine any machine shank available in our assortment, with any tool dimension (12 – 32 mm). With an

intermediate sleeve, ETP offers you your customized toolholder to any required gauge length (up to 250 mm).

These customized toolholders offer the same rigid solid design, dampening properties and high runout precision as our standard assortment.

Design your own hydraulic precision toolholder - Online customized.etp.se



BENEFITS & FEATURES

- Maximum flexibility in your design
- Choose your required gauge line length
- Radial length adjustment module possible



Tough and slender design

ETP HYDRO-GRIP® G2 SLENDER

HYDRO-GRIP type SLENDER is extremely user friendly which means quick and easy tool changes. It has a tough and slender design.

Hydraulic high precision toolholders



BENEFITS & FEATURES

- Quick and easy tool change
- High performance
- Slender design
- Excellent runout



Hydraulic high precision toolholders – Pencil version



ETP HYDRO-GRIP® PENCIL

ETP HYDRO-GRIP® PENCIL is with its extreme slim design one of the most versatile holder on the market. An extensive range of standard dimensions and lengths optimizes your productivity when

machining deep cavities and complex components. ETP HYDRO-GRIP® PENCIL can also be made to your specific gauge line requirement, using our Customized Designs possibility.

BENEFITS & FEATURES

- For drilling to finishing
- Pencil design enabling machining in deep cavities and complex components
- Special designs possibility
- High clamping force



ETP HYDRO-GRIP® Grinding holder

We are happy to introduce our newest addition to the range of high quality hydraulic toolholders – HYDRO-GRIP Grinding holder.

With the combination of extreme high precision and easy handling and tool change a massive improvement in

productivity can be reached. Quicker set-up times and improved repeat accuracy during sharpening of tools will save you time and money. The possibility to use reduction sleeves in the hydraulic holder also increases your flexibility.



BENEFITS & FEATURES

- High run-out accuracy $\leq 0,004$ mm (≤ 0.00016 inch)
- Easy handling and tool change
- High clamping force
- Vibration dampening
- Flexibility in clamping range – use of reducing sleeves possible

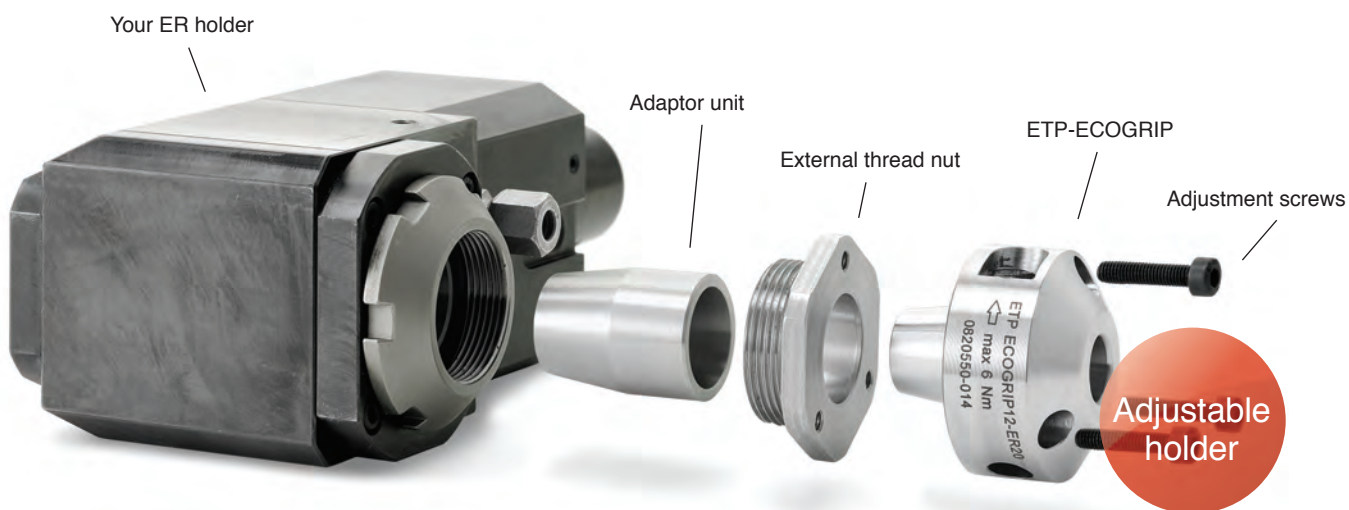
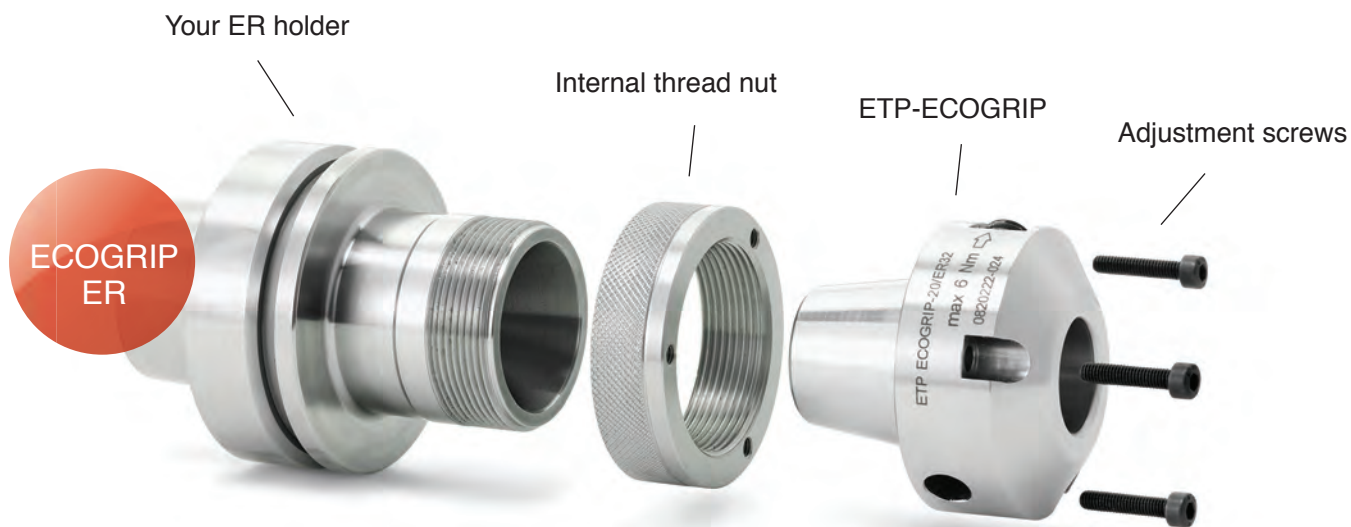

Make your ER holder hydraulic and enjoy multiple benefits

ETP ECOGRIP™ ER

With the ETP ECOGRIP ER hydraulic sleeves you can easily turn your standard ER collet holder into a high precision hydraulic holder. Thus you can easily enjoy all the positive benefits of hydraulic clamping such as easy handling and precision, at an

impressive competitive price level. This enables more users to benefit from decrease tool wear and increase productivity compared to using ER collet holders. With the use of the three axial screws an adjustability of the run-out is achieved.



BENEFITS & FEATURES

- Turning ER holders hydraulic
- Easy handling and precision
- Adjustability of run-out

ETP HYDRO-GRIP®

HSK Form A - DIN 69893

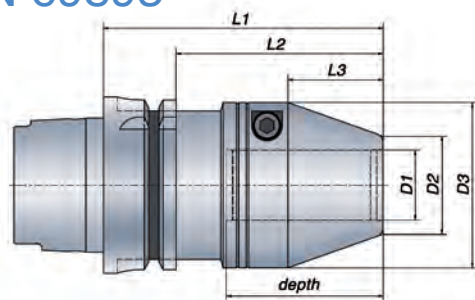

Metric range

Technical Specification HSK form A

HSK size	Part no.	Item description	Dimensions, mm										
			D1	D2	D3	L1	L2	L3	depth	T* Nm	Weight kg	G 2.5 at rpm	
●	63	685630	HG-12/HSK63A	12	22	43.5	76	50	18	40	60 - 125	1.1	25 000
●		685640	HG-12x100/HSK63A	12	22	43.5	100	74	18	40	60 - 125	1.4	25 000
○		685650	HG-16/HSK63A	16	26	48	86	60	28	50	165 - 270	1.2	25 000
○		685660	HG-16x125/HSK63A	16	20	48	125	99	28	50	165 - 270	1.8	25 000
●		685670	HG-20/HSK63A	20	30	52	88	62	30	52	260 - 425	1.3	25 000
●		685680	HG-20x150/HSK63A	20	30	52	150	124	30	52	260 - 425	2.3	25 000
●		685690	HG-25/HSK63A	25	35	59	100	74	34	56	480 - 710	1.6	25 000
●		685700	HG-25x150/HSK63A	25	35	59	150	124	34	56	480 - 710	2.7	25 000
●		685710	HG-32/HSK63A	32	42	69.5	105	79	38	60	820 - 1250	2.0	25 000
●	100	685720	HG-12/HSK100A	12	22	43.5	79	50	18	40	60 - 125	2.4	14 000
●		685730	HG-12x100/HSK100A	12	22	43.5	100	71	18	40	60 - 125	2.7	14 000
○		685740	HG-16/HSK100A	16	26	48	89	60	28	50	165 - 270	2.6	14 000
○		685750	HG-16x125/HSK100A	16	26	48	125	96	28	50	165 - 270	3.1	14 000
●		685760	HG-20/HSK100A	20	30	52	91	62	30	52	260 - 425	2.7	14 000
●		685770	HG-20x150/HSK100A	20	30	52	150	121	30	52	260 - 425	3.6	14 000
●		685780	HG-25/HSK100A	25	35	59	95	66	34	56	480 - 710	2.9	14 000
●		685790	HG-25x150/HSK100A	25	35	59	150	121	34	56	480 - 710	4.0	14 000
●		685800	HG-32/HSK100A	32	42	69.5	99	70	38	60	820 - 1250	3.3	14 000

Inch range

Technical Specification HSK form A

HSK size	Part no.	Item description	Dimensions, inch										
			D1	D2	D3	L1	L2	L3	depth	T* ft-lb	Weight kg	G 2.5 at rpm	
●	63	685630-T	HG-1/2"/HSK63A	0.500	0.866	1.713	2.992	1.969	0.709	1.575	55 - 105	1.1	25 000
○		685640-T	HG-1/2"x100/HSK63A	0.500	0.866	1.713	3.937	2.913	0.709	1.575	55 - 105	1.4	25 000
●		685670-T	HG-3/4"/HSK63A	0.750	1.181	2.047	3.465	2.441	1.181	2.047	192 - 314	1.3	25 000
●		685680-T	HG-3/4"x150/HSK63A	0.750	1.181	2.047	5.906	4.882	1.181	2.047	192 - 314	2.3	25 000
●		685690-T	HG-1"/HSK63A	1.000	1.378	2.323	3.937	2.913	1.339	2.205	354 - 524	1.6	25 000
○		685700-T	HG-1"x150/HSK63A	1.000	1.378	2.323	5.906	4.882	1.339	2.205	354 - 524	2.7	25 000
●		685710-T	HG-1 1/4"/HSK63A	1.250	1.654	2.736	4.134	3.110	1.496	2.362	605 - 922	2.0	25 000
○	100	685720-T	HG-1/2"/HSK100A	0.500	0.866	1.713	3.110	1.969	0.709	1.575	55 - 105	2.4	14 000
○		685730-T	HG-1/2"x100/HSK100A	0.500	0.866	1.713	3.937	2.795	0.709	1.575	55 - 105	2.7	14 000
●		685760-T	HG-3/4"/HSK100A	0.750	1.181	2.047	3.583	2.441	1.181	2.047	192 - 314	2.7	14 000
○		685770-T	HG-3/4"x150/HSK100A	0.750	1.181	2.047	5.906	4.764	1.181	2.047	192 - 314	3.6	14 000
●		685780-T	HG-1"/HSK100A	1.000	1.378	2.323	3.740	2.598	1.339	2.205	354 - 524	2.9	14 000
○		685790-T	HG-1"x150/HSK100A	1.000	1.378	2.323	5.906	4.764	1.339	2.205	354 - 524	4.0	14 000
●		685800-T	HG-1 1/4"/HSK100A	1.250	1.654	2.736	3.898	2.756	1.496	2.362	605 - 922	3.3	14 000

*) T = Min. and Max. transmittable torque using a h6 cylindrical tool, full depth insert. For additional information see section Technical Information.

- From stock
- On request

Information:

- Runout accuracy < 0.004 mm at 2.5 x D1 (max. 50 mm)
≤ 0.00016 inch at 2.5x D1 (max. 1.969 inch)
- Tool shank h6 or h7 can be used
- Center thread, M8x1.25, for axial length adjustment screw (screw not included)
- Coolant through on all holders
- Bore for data carrier

Accessories:

Use preset Torque Wrench, 6 Nm, to ensure correct mounting of tools. Part no. 19050

ETP HYDRO-GRIP can be used with reducing sleeves. For additional information see section Accessories.



ETP HYDRO-GRIP® HD

HSK Form A - DIN 69893

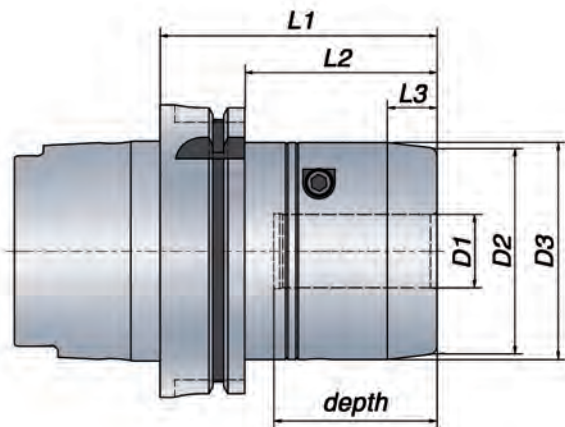

Metric range

Technical Specification HSK form A

HSK size	Part no.	Item description	Dimensions, mm							depth	T* Nm	Weight kg	G 2.5 at rpm
			D1	D2	D3	L1	L2	L3					
● 63	682150	HG HD-20/HSK63A	20	59	63	96	70	17	52	400 - 535	2.0	25 000	
● 100	682160	HG HD-20/HSK100A	20	59	63	91	62	17	52	400 - 535	3.3	14 000	
●	682170	HG HD-25/HSK100A	25	70	74	95	66	17	56	740 - 940	3.9	14 000	
●	682180	HG HD-32/HSK100A	32	76	80	99	70	17	60	1325 - 1670	4.2	14 000	

Inch range

Technical Specification HSK form A

HSK size	Part no.	Item description	Dimensions, inch							depth	T* ft·lb	Weight kg	G 2.5 at rpm
			D1	D2	D3	L1	L2	L3					
● 63	682150-T	HG HD-3/4"/HSK63A	0.750	2.323	2.480	3.780	2.756	0.669	2.047	295 - 395	2.0	25 000	
○ 100	682160-T	HG HD-3/4"/HSK100A	0.750	2.323	2.480	3.583	2.441	0.669	2.047	295 - 395	3.3	14 000	
○	682170-T	HG HD-1"/HSK100A	1.000	2.756	2.913	3.740	2.598	0.669	2.205	546 - 693	3.9	14 000	
●	682180-T	HG HD-1 1/4"/HSK100A	1.250	2.992	3.150	3.898	2.756	0.669	2.362	977 - 1232	4.2	14 000	

*) T = Min. and Max. transmittable torque using a h6 cylindrical tool, full depth insert. For additional information see section Technical Information.

- From stock
- On request

Information:

- Runout accuracy < 0.004 mm at 2.5 x D1 (max. 50 mm)
≤ 0.00016 inch at 2.5x D1 (max. 1.969 inch)
- Tool shank h6 or h7 can be used
- Center thread, M12x1, for axial length adjustment screw (screw not included)
- Coolant through on all holders
- Bore for data carrier

Accessories:

Use preset Torque Wrench, 10 Nm, to ensure correct mounting of tools. Part no. 19052

ETP HYDRO-GRIP HD can be used with reducing sleeves. For additional information see section Accessories.



ETP HYDRO-GRIP® PENCIL HSK Form A - DIN 69893

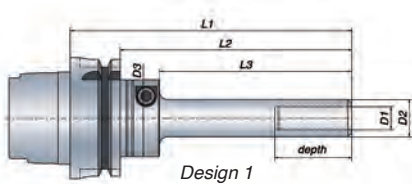

Design 1

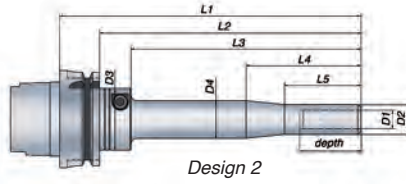

Design 2

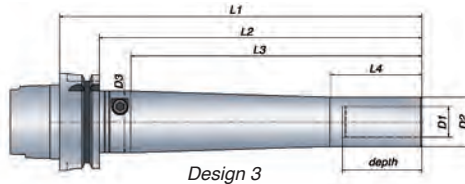

Design 3



Metric range

Technical Specification HSK form A

Design	HSK size	Part no.	Item description	Dimensions, mm												T* Nm	Weight kg	G 2.5 at rpm
				D1	D2	D3	D4	L1	L2	L3	L4	L5	depth					
● 1	63	683810	HG PENCIL-6x50/HSK63A	6	12	40		96.5	70.5	50					40	12-22	0.9	25 000
○ 1		683740	HG PENCIL-8x50/HSK63A	8	14.5	40		96.5	70.5	50					40	27-40	0.9	25 000
○ 1		683760	HG PENCIL-10x50/HSK63A	10	17	40		96.5	70.5	50					40	35-70	0.9	25 000
○ 1		683750	HG PENCIL-10x100/HSK63A	10	17	40		146.5	120.5	100					40	35-70	1.0	15 000
● 1		683830	HG PENCIL-12x50/HSK63A	12	19.5	40		96.5	70.5	50					40	60-125	0.9	25 000
● 1		683840	HG PENCIL-12x100/HSK63A	12	19.5	40		146.5	120.5	100					40	60-125	1.0	15 000
● 2		683820	HG PENCIL-12x150/HSK63A	12	19.5	40	24.5	196.5	170.5	150	75	50			40	60-125	1.2	10 000
○ 1		683780	HG PENCIL-16x75/HSK63A	16	26	40		121.5	95.5	75					50	165-270	1.1	15 000
○ 1		683770	HG PENCIL-16x125/HSK63A	16	26	40		171.5	145.5	125					50	165-270	1.3	10 000
● 3		683790	HG PENCIL-20x110/HSK63A	20	32	40		156.5	130.5	110	60				52	260-425	1.5	20 000
● 3		683800	HG PENCIL-20x190/HSK63A	20	32	40		236.5	210.5	190	60				52	260-425	2.1	10 000
○ 1	100	683860	HG PENCIL-10x50/HSK100A	10	17	40		117	88	50					40	35-70	2.4	14 000
○ 1		683850	HG PENCIL-10x100/HSK100A	10	17	40		167	138	100					40	35-70	2.5	14 000
○ 1		683890	HG PENCIL-12x50/HSK100A	12	19.5	40		117	88	50					40	60-125	2.4	14 000
● 1		683920	HG PENCIL-12x100/HSK100A	12	19.5	40		167	138	100					40	60-125	2.5	14 000
● 2		683930	HG PENCIL-12x150/HSK100A	12	19.5	40	24.5	217	188	150	75	50			40	60-125	2.7	10 000
○ 1		683880	HG PENCIL-16x75/HSK100A	16	26	40		142	113	75					50	165-270	2.6	14 000
○ 1		683870	HG PENCIL-16x125/HSK100A	16	26	40		192	163	125					50	165-270	2.8	10 000
● 3		683900	HG PENCIL-20x110/HSK100A	20	32	40		177	148	110	60				52	260-425	3.0	14 000
● 3		683910	HG PENCIL-20x190/HSK100A	20	32	40		257	228	190	60				52	260-425	3.6	10 000

Inch range

Technical Specification HSK form A

Design	HSK size	Part no.	Item description	Dimensions, inch												T* ft-lb	Weight kg	G 2.5 at rpm
				D1	D2	D3	D4	L1	L2	L3	L4	L5	depth					
● 1	63	683810-T	HG PENCIL-1/4"x50/HSK63A	0.250	0.472	1.575		3.799	2.776	1.969					1.575	13-20	0.9	25 000
● 1		683830-T	HG PENCIL-1/2"x50/HSK63A	0.500	0.768	1.575		3.799	2.776	1.969					1.575	55-105	0.9	25 000
● 1		683840-T	HG PENCIL-1/2"x100/HSK63A	0.500	0.768	1.575		5.768	4.744	3.937					1.575	55-105	1.0	15 000
● 2		683820-T	HG PENCIL-1/2"x150/HSK63A	0.500	0.768	1.575	0.965	7.736	6.713	5.906	2.953	1.969			1.575	55-105	1.2	10 000
● 3		683790-T	HG PENCIL-3/4"x110/HSK63A	0.750	1.260	1.575		6.161	5.138	4.331	2.362				2.047	192-314	1.5	20 000
● 3		683800-T	HG PENCIL-3/4"x190/HSK63A	0.750	1.260	1.575		9.311	8.287	7.480	2.362				2.047	192-314	2.1	10 000
● 1	100	683890-T	HG PENCIL-1/2"x50/HSK100A	0.500	0.768	1.575		4.606	3.465	1.969					1.575	55-105	2.4	14 000
● 1		683920-T	HG PENCIL-1/2"x100/HSK100A	0.500	0.768	1.575		6.575	5.433	3.937					1.575	55-105	2.5	14 000
● 2		683930-T	HG PENCIL-1/2"x150/HSK100A	0.500	0.768	1.575	0.965	8.543	7.402	5.906	2.953	1.969			1.575	55-105	2.7	10 000
● 3		683900-T	HG PENCIL-3/4"x110/HSK100A	0.750	1.260	1.575		6.969	5.827	4.331	2.362				2.047	192-314	3.0	14 000
● 3		683910-T	HG PENCIL-3/4"x190/HSK100A	0.750	1.260	1.575		10.118	8.976	7.480	2.362				2.047	192-314	3.6	10 000

*) T = Min. and Max. transmittable torque using a h6 cylindrical tool, full depth insert. For additional information see section Technical Information.

- From stock
- On request

Information:

- Runout accuracy < 0.004 mm at 2.5 x D1 (max. 50 mm)
≤ 0.00016 inch at 2.5 x D1 (max. 1.969 inch)
- ≤ 0.007 mm at 2.5 x D1 at length L1 > 125 mm
≤ 0.00028 inch at 2.5 x D1 at length L1 > 4.921 inch
- Tool shank h6 or h7 can be used
- Coolant through on all holders
- Bore for data carrier

Accessories:

Use preset Torque Wrench, 6 Nm, to ensure correct mounting of tools. Part no. 19050

ETP HYDRO-GRIP PENCIL can be used with reducing sleeves.

For additional information see section Accessories.



ETP HYDRO-GRIP®

HSK Form C - DIN 69893

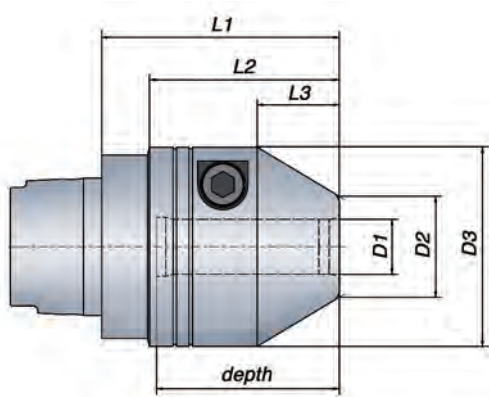

Technical Specification HSK form C

HSK size	Part no.	Item description	Dimensions, mm									
			D1	D2	D3	L1	L2	L3	depth	T*	Weight kg	G 2.5 at rpm
● 32	705667	HG-12/HSK32C	12	22	43.5	52	40.5	18	40	60-125	0.4	25 000
● 40	705668	HG-12/HSK40C	12	22	43.5	52	41.5	18	40	60-125	0.5	25 000
○ 50	705716	HG-20/HSK50C	20	30	52	67	54.5	30	52	260-425	0.8	25 000

*) T = Min. and Max. transmittable torque using a h6 cylindrical tool, full depth insert. For additional information see section Technical Information.

- From stock
- On request

Information:

- Runout accuracy ≤ 0.004 mm at $2.5 \times D1$ (max. 50 mm)
 ≤ 0.00016 inch at $2.5 \times D1$ (max. 1.969 inch)
- Tool shank h6 or h7 can be used
- Center thread, M8x1.25, for axial length adjustment screw (screw not included)
- Coolant through on all holders
- Bore for data carrier

Accessories:

Use preset Torque Wrench, 6 Nm, to ensure correct mounting of tools. Part no. 19050.

ETP HYDRO-GRIP can be used with reducing sleeves.
For additional information see section Accessories.



ETP HYDRO-GRIP®

HSK Form C - For HYDROMAT® Rotary transfer machines

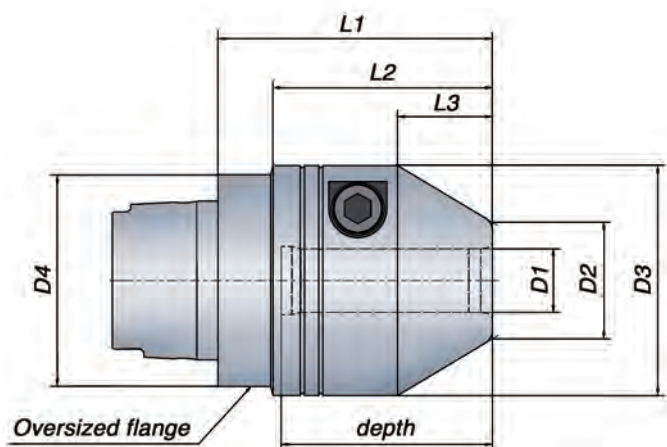

Technical Specification HSK form C													
HSK size	Part no.	Item description	Dimensions, mm										
			D1	D2	D3	D4	L1	L2	L3	depth	T* Nm	Weight kg	G 2.5 at rpm
○ 32	705727	HG-12/HSK32C - HM40	12	22	43.5	40	52	41.5	18	40	60-125	0.4	25 000
○ 40	705728	HG-20/HSK40C - HM50	20	30	52	50	64	53.7	30	52	260-425	0.7	25 000
○ 50	705729	HG-32/HSK50C - HM63	32	42	69.5	63	85	64.1	38	60	820-1250	1.6	25 000

*) T = Min. and Max. transmittable torque using a h6 cylindrical tool, full depth insert. For additional information see section Technical Information.

- From stock
- On request

Information:

- Runout accuracy ≤ 0.004 mm at $2.5 \times D1$ (max. 50 mm)
 ≤ 0.00016 inch at $2.5 \times D1$ (max. 1.969 inch)
- Tool shank h6 or h7 can be used
- Center thread, M8x1.25, for axial length adjustment screw (screw not included)
- Coolant through on all holders
- Bore for data carrier

Accessories:

Use preset Torque Wrench, 6 Nm, to ensure correct mounting of tools. Part no. 19050.

ETP HYDRO-GRIP can be used with reducing sleeves. For additional information see section Accessories.



ETP HYDRO-GRIP® COMPACT HSK Form F - DIN 69893

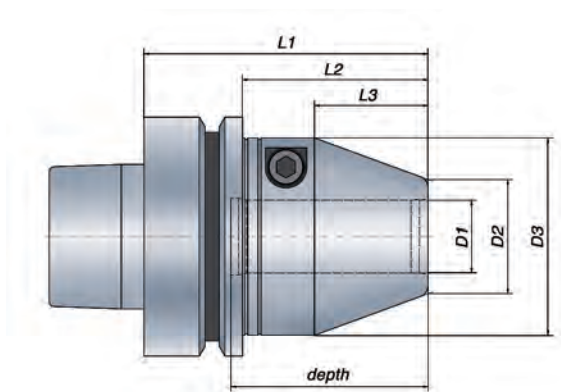

Metric range

Technical Specification HSK form F

HSK size	Part no.	Item description	Dimensions, mm									
			D1	D2	D3	L1	L2	L3	depth	T* Nm	Weight kg	G 2.5 at rpm
● 63	705762	HG COMPACT-12/HSK63F	12	22	43.5	75	49	18	40	60 - 125	1.1	25 000
●	705764	HG COMPACT-16/HSK63F	16	26	48	75	49	28	50	165 - 270	1.1	25 000
●	705766	HG COMPACT-20/HSK63F	20	30	52	75	49	30	52	260 - 425	1.1	25 000

Inch range

Technical Specification HSK form F

HSK size	Part no.	Item description	Dimensions, inch									
			D1	D2	D3	L1	L2	L3	depth	T* ft-lb	Weight kg	G 2.5 at rpm
● 63	705763	HG COMPACT-1/2"/HSK63F	0.500	0.866	1.713	2.953	1.929	0.709	1.575	55 - 105	1.1	25 000
●	705765	HG COMPACT-5/8"/HSK63F	0.625	1.024	1.890	2.953	1.929	1.102	1.969	122 - 199	1.1	25 000
●	705681	HG COMPACT-3/4"/HSK63F	0.750	1.181	2.047	2.953	1.929	1.181	2.047	192 - 314	1.1	25 000

*) T = Min. and Max. transmittable torque using a h6 cylindrical tool, full depth insert. For additional information see section Technical Information.

- From stock
- On request

Information:

- Runout accuracy ≤ 0.004 mm at $2.5 \times D1$ (max. 50 mm)
 ≤ 0.00016 inch at $2.5 \times D1$ (max. 1.969 inch)
- Tool shank h6 or h7 can be used

Accessories:

Use preset Torque Wrench, 6 Nm, to ensure correct mounting of tools. Part no. 19050.

ETP HYDRO-GRIP COMPACT can be used with reducing sleeves.
For additional information see section Accessories.



ETP HYDRO-GRIP® G2 SLENDER HSK Form F - DIN 69893

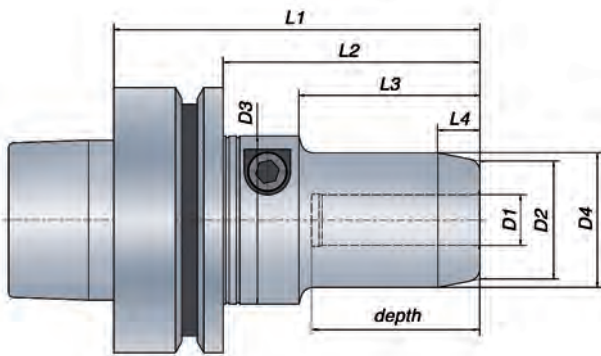

Metric range

Technical Specification HSK form F

HSK size	Part no.	Item description	Dimensions, mm											T* Nm	Weight kg	G 2.5 at rpm
			D1	D2	D3	D4	L1	L2	L3	L4	depth					
● 63	642680	HG G2 SLENDER-12/HSK63F	12	28	40	32	87	61	43	10	40	60-125	1	25 000		
●	642690	HG G2 SLENDER-16/HSK63F	16	34	40	38	87	61	43	10	40	165-270	1.1	25 000		
●	642700	HG G2 SLENDER-20/HSK63F	20	36	50	40	99	73	55	10	52	260-425	1.3	25 000		
●	639130	HG G2 SLENDER-25/HSK63F	25	41	50	45	103	77	59	10	56	480-710	1.4	25 000		

Inch range

Technical Specification HSK form F

HSK size	Part no.	Item description	Dimensions, inch											T* ft·lb	Weight kg	G 2.5 at rpm
			D1	D2	D3	D4	L1	L2	L3	L4	depth					
● 63	659400	HG G2 SLENDER-3/8"/HSK63F	0.375	1.102	1.575	1.260	3.425	2.402	1.693	0.394	1.575	22-52	1	25 000		
●	642710	HG G2 SLENDER-1/2"/HSK63F	0.500	1.339	1.575	1.260	3.425	2.402	1.693	0.394	1.575	55-105	1	25 000		
●	642720	HG G2 SLENDER-5/8"/HSK63F	0.625	1.339	1.575	1.496	3.425	2.402	1.693	0.394	1.575	122-199	1.1	25 000		
●	642730	HG G2 SLENDER-3/4"/HSK63F	0.750	1.417	1.969	1.575	3.898	2.874	2.165	0.394	2.047	192-314	1.3	25 000		
●	639140	HG G2 SLENDER-1"/HSK63F	1.000	1.614	1.969	1.772	4.055	3.031	2.323	0.394	2.205	354-524	1.4	25 000		

*) T = Min. and Max. transmittable torque using a h6 cylindrical tool, full depth insert. For additional information see section Technical Information.

- From stock
- On request

Information:

- Runout accuracy ≤ 0.004 mm at $2.5 \times D1$ (max. 50 mm),
 ≤ 0.00016 inch at $2.5 \times D1$ (max. 1.969 inch)
- Tool shank h6 or h7 can be used

Accessories:

Use preset Torque Wrench, 6 Nm, to ensure correct mounting of tools. Part no. 19050.

ETP HYDRO-GRIP SLENDER can be used with reducing sleeves.
For additional information see section Accessories.



ETP HYDRO-GRIP® PENCIL HSK Form F - DIN 69893

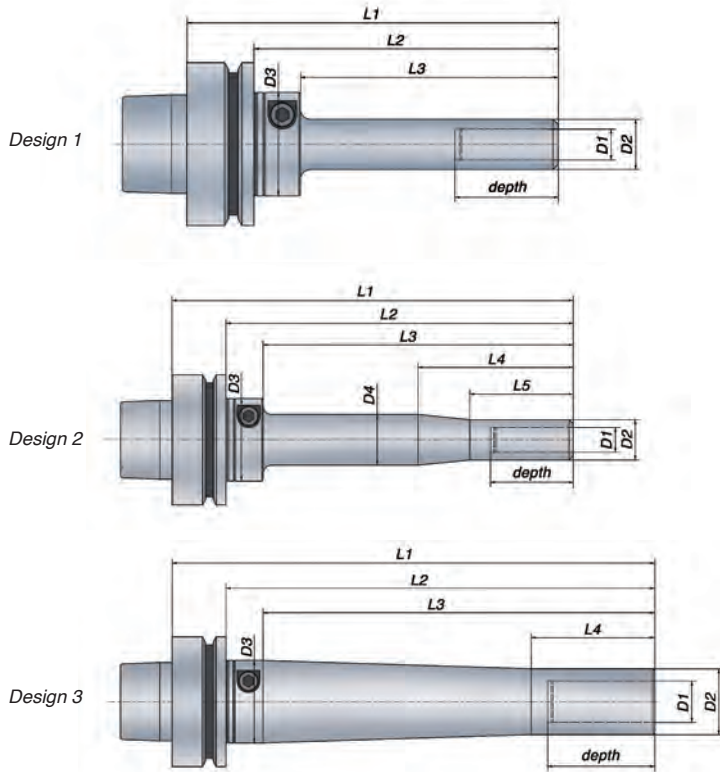

Metric range

Technical Specification HSK form F

Design	HSK size	Part no.	Item description	Dimensions, mm												T* Nm	Weight kg	G 2.5 at rpm
				D1	D2	D3	D4	L1	L2	L3	L4	L5	depth					
● 1	63	684400	HG PENCIL-6x50/HSK63F	6	12	40		94	68	50				40	12-22	0.8	25 000	
● 1		684440	HG PENCIL-12x50/HSK63F	12	19.5	40		94	68	50				40	60-125	0.9	25 000	
● 1		684450	HG PENCIL-12x100/HSK63F	12	19.5	40		144	118	100				40	60-125	1	15 000	
● 2		684460	HG PENCIL-12x150/HSK63F	12	19.5	40	24.5	194	168	150	75	50	40	60-125	1.2	10 000		
● 3		684490	HG PENCIL-20x110/HSK63F	20	32	40		154	128	110	60		52	260-425	1.4	20 000		
● 3		684500	HG PENCIL-20x190/HSK63F	20	32	40		234	208	190	60		52	260-425	2.1	10 000		

Inch range

Technical Specification HSK form F

Design	HSK size	Part no.	Item description	Dimensions, inch												T* ft-lb	Weight kg	G 2.5 at rpm
				D1	D2	D3	D4	L1	L2	L3	L4	L5	depth					
● 1	63	684540	HG PENCIL-1/2"x50/HSK63F	0.500	0.768	1.575		3.701	2.677	1.969				1.575	55-105	0.9	25 000	
● 1		684550	HG PENCIL-1/2"x100/HSK63F	0.500	0.768	1.575		5.669	4.646	3.937				1.575	55-105	1	15 000	
● 2		684560	HG PENCIL-1/2"x150/HSK63F	0.500	0.768	1.575	0.965	7.638	6.614	5.906	2.953	1.969	1.575	55-105	1.2	10 000		
● 3		684590	HG PENCIL-3/4"x110/HSK63F	0.750	1.260	1.575		6.063	5.039	4.331	2.362		2.047	192-314	1.4	20 000		
● 3		684600	HG PENCIL-3/4"x190/HSK63F	0.750	1.260	1.575		9.213	8.189	7.480	2.362		2.047	192-314	2.1	10 000		

*) T = Min. and Max. transmittable torque using a h6 cylindrical tool, full depth insert. For additional information see section Technical Information.

- From stock
- On request

Information:

- Runout accuracy < 0.004 mm at 2.5 x D1 (max. 50 mm)
 ≤0.00016 inch at 2.5 x D1 (max. 1.969 inch)
 ≤0.007 mm at 2.5 x D1 at length L1 > 125 mm
 ≤0.00028 inch at 2.5 x D1 at length L1 > 4.921 inch
- Tool shank h6 or h7 can be used
- Coolant through on all holders

Accessories:

Use preset Torque Wrench, 6 Nm, to ensure correct mounting of tools. Part no. 19050

ETP HYDRO-GRIP PENCIL can be used with reducing sleeves.

For additional information see section Accessories.



ETP HYDRO-GRIP®

ISO Form AD/B - 7388-1

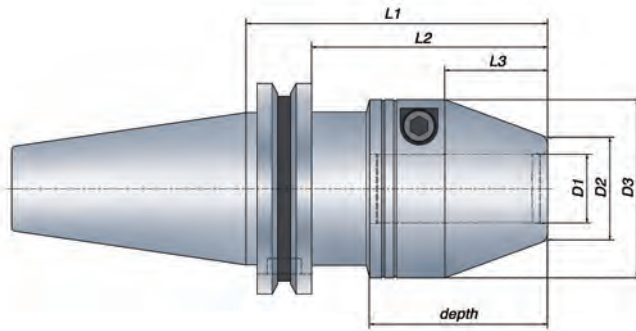

Metric range

Technical Specification ISO form AD/B

Taper	Part no.	Item description	Dimensions, mm									T* Nm	Weight kg	G 2.5 at rpm
			D1	D2	D3	L1	L2	L3	depth					
●	685810	HG-12/ISO40	12	22	43.5	56	36.9	18	40	60-125	1.1	25 000		
	685820	HG-12x100/ISO40	12	22	43.5	100	80.9	18	40	60-125	1.6	25 000		
	685830	HG-16/ISO40	16	26	48	73	53.9	28	50	165-270	1.3	25 000		
	685840	HG-16x125/ISO40	16	26	48	125	105.9	28	50	165-270	2.1	25 000		
	685850	HG-20/ISO40	20	30	52	88	68.9	30	52	260-425	1.6	25 000		
	685860	HG-20x125/ISO40	20	30	52	125	105.9	30	52	260-425	2.2	25 000		
○	685870	HG-25/ISO40	25	35	59	93	73.9	34	56	480-710	1.7	25 000		
	685880	HG-12/ISO50	12	22	43.5	56	36.9	18	40	60-125	2.9	14 000		
	685890	HG-12x100/ISO50	12	22	43.5	100	80.9	18	40	60-125	3.4	14 000		
	685900	HG-16/ISO50	16	26	48	66	46.9	28	50	165-270	3.1	14 000		
	685910	HG-16x125/ISO50	16	26	48	125	105.9	28	50	165-270	3.9	14 000		
	685920	HG-20/ISO50	20	30	52	68	48.9	30	52	260-425	3.1	14 000		
	685930	HG-20x150/ISO50	20	30	52	150	130.9	30	52	260-425	4.5	14 000		
	685940	HG-25/ISO50	25	35	59	72	52.9	34	56	480-710	3.3	14 000		
	685950	HG-25x150/ISO50	25	35	59	150	130.9	34	56	480-710	4.9	14 000		
	685960	HG-32/ISO50	32	42	69.5	77	57.9	38	60	820-1250	3.6	14 000		

Inch range

Technical Specification ISO form AD/B

Taper	Part no.	Item description	Dimensions, inch									T* ft·lb	Weight kg	G 2.5 at rpm
			D1	D2	D3	L1	L2	L3	depth					
○	685810-T	HG-1/2"/ISO40	0.500	0.866	1.713	2.205	1.453	0.709	1.575	55-105	1.1	25 000		
	685820-T	HG-1/2"x100/ISO40	0.500	0.866	1.713	3.937	3.185	0.709	1.575	55-105	1.6	25 000		
	685850-T	HG-3/4"/ISO40	0.750	1.181	2.047	3.465	2.713	1.181	2.047	192-314	1.6	25 000		
	685860-T	HG-3/4"x125/ISO40	0.750	1.181	2.047	4.921	4.169	1.181	2.047	192-314	2.2	25 000		
	685870-T	HG-1"/ISO40	1.000	1.378	2.323	3.661	2.909	1.339	2.205	354-524	1.7	25 000		
○	685920-T	HG-3/4"/ISO50	0.750	1.181	2.047	2.677	1.925	1.181	2.047	192-314	3.1	14 000		
	685930-T	HG-3/4"x150/ISO50	0.750	1.181	2.047	5.906	5.154	1.181	2.047	192-314	4.5	14 000		
	685940-T	HG-1"/ISO50	1.000	1.378	2.323	2.835	2.083	1.339	2.205	354-524	3.3	14 000		
	685950-T	HG-1"x150/ISO50	1.000	1.378	2.323	5.906	5.154	1.339	2.205	354-524	4.9	14 000		
	685960-T	HG-1 1/4"/ISO50	1.250	1.654	2.736	3.031	2.280	1.496	2.362	605-922	3.6	14 000		

*) T = Min. and Max. transmittable torque using a h6 cylindrical tool, full depth insert. For additional information see section Technical Information.

- From stock
- On request

Information:

- Runout accuracy < 0.004 mm at 2.5 x D1 (max. 50 mm)
- ≤ 0.00016 inch at 2.5x D1 (max. 1.969 inch)
- Tool shank h6 or h7 can be used
- Center thread, M8x1.25, for axial length adjustment screw (screw not included)
- Coolant through on all holders
- Bore for data carrier

Accessories:

Use preset Torque Wrench, 6 Nm, to ensure correct mounting of tools. Part no. 19050

ETP HYDRO-GRIP can be used with reducing sleeves. For additional information see section Accessories.



ETP HYDRO-GRIP® HD

ISO Form AD - 7388-1

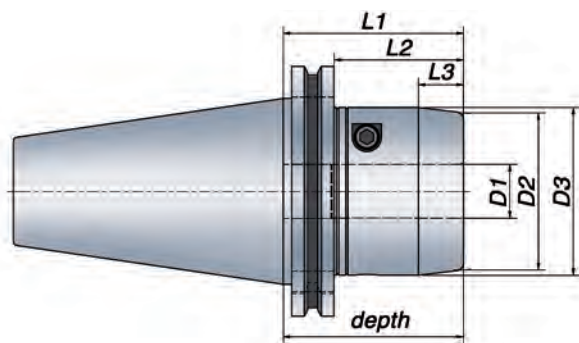

Metric range

Technical Specification ISO form AD

Taper	Part no.	Item description	Dimensions, mm								T* Nm	Weight kg	G 2.5 at rpm
			D1	D2	D3	L1	L2	L3	depth				
●	40	682190	HG HD-20/ISO40	20	59	63	90	70.9	17	90	400-535	2.1	25 000
●	50	682200	HG HD-20/ISO50	20	59	63	68	48.9	17	68	400-535	3.5	14 000
●		682210	HG HD-25/ISO50	25	70	74	79	59.9	17	79	740-940	4.2	14 000
●		682220	HG HD-32/ISO50	32	76	80	83	63.9	17	83	1325-1670	4.4	14 000

Inch range

Technical Specification ISO form AD

Taper	Part no.	Item description	Dimensions, inch								T* ft-lb	Weight kg	G 2.5 at rpm
			D1	D2	D3	L1	L2	L3	depth				
○	40	682190-T	HG HD-3/4"/ISO40	0.750	2.323	2.480	3.543	2.791	0.669	3.543	295-395	2.1	25 000
○	50	682200-T	HG HD-3/4"/ISO50	0.750	2.323	2.480	2.677	1.925	0.669	2.677	295-395	3.5	14 000
○		682210-T	HG HD-1"/ISO50	1.000	2.756	2.913	3.110	2.358	0.669	3.110	546-693	4.2	14 000
○		682220-T	HG HD-1 1/4"/ISO50	1.250	2.992	3.150	3.268	2.516	0.669	3.268	977-1232	4.4	14 000

*) T = Min. and Max. transmittable torque using a h6 cylindrical tool, full depth insert. For additional information see section Technical Information.

- From stock
- On request

Information:

- Runout accuracy < 0.004 mm at 2.5 x D1 (max. 50 mm) ≤ 0.00016 inch at 2.5x D1 (max. 1.969 inch)
- Tool shank h6 or h7 can be used
- Center thread, M12x1, for axial length adjustment screw (screw not included)
- Coolant through on all holders
- Bore for data carrier - available on request

Accessories:

Use preset Torque Wrench, 10 Nm, to ensure correct mounting of tools. Part no. 19052

ETP HYDRO-GRIP HD can be used with reducing sleeves. For additional information see section Accessories.



ETP HYDRO-GRIP® PENCIL ISO Form AD/B - 7388-1

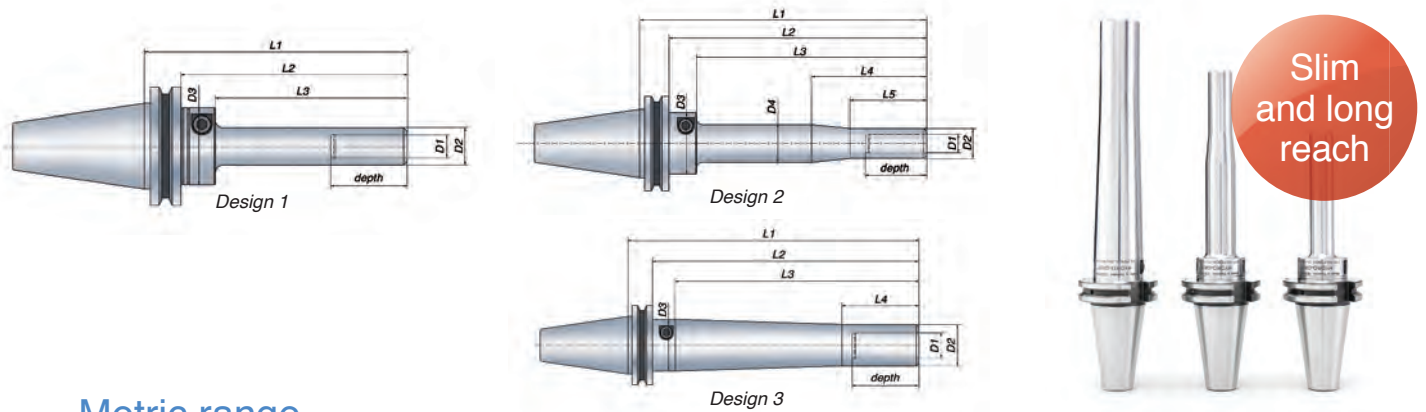

Metric range

Technical Specification ISO form AD/B

Design	Taper	Part no.	Item description	Dimensions, mm														
				D1	D2	D3	D4	L1	L2	L3	L4	L5	depth	T* Nm	Weight kg	G 2.5 at rpm		
● 1	40	683940	HG PENCIL-6x50/ISO40	6	12	40		87	67.9	50					40	12-22	1	25 000
○ 1		683950	HG PENCIL-8x50/ISO40	8	14.5	40		87	67.9	50					40	27-40	1	25 000
○ 1		683970	HG PENCIL-10x50/ISO40	10	17	40		87	67.9	50					40	35-70	1	25 000
○ 1		683960	HG PENCIL-10x100/ISO40	10	17	40		137	117.9	100					40	35-70	1.1	15 000
● 1		684000	HG PENCIL-12x50/ISO40	12	19.5	40		87	67.9	50					40	60-125	1.1	25 000
● 1		684010	HG PENCIL-12x100/ISO40	12	19.5	40		137	117.9	100					40	60-125	1.2	15 000
● 2		684030	HG PENCIL-12x150/ISO40	12	19.5	40	24.5	187	167.9	150	75	50			40	60-125	1.4	10 000
○ 1		683990	HG PENCIL-16x75/ISO40	16	26	40		112	92.9	75					50	165-270	1.2	15 000
○ 1		683980	HG PENCIL-16x125/ISO40	16	26	40		162	142.9	125					50	165-270	1.4	10 000
● 3		684020	HG PENCIL-20x110/ISO40	20	32	40		147	127.9	110	60				52	260-425	1.6	20 000
● 3		684040	HG PENCIL-20x190/ISO40	20	32	40		227	207.9	190	60				52	260-425	2.3	10 000
● 1	50	684190	HG PENCIL 12x50/ISO50	12	19.5	40		87	67.9	50					40	60-125	2.9	14 000
● 1		684200	HG PENCIL 12x100/ISO50	12	19.5	40		137	117.9	100					40	60-125	3	14 000
● 2		684210	HG PENCIL 12x150/ISO50	12	19.5	40	24.5	187	167.9	150	75	50			40	60-125	3.2	10 000
● 3		684240	HG PENCIL 20x110/ISO50	20	32	40		147	127.9	110	60				52	260-425	3.4	14 000
● 3		684250	HG PENCIL 20x190/ISO50	20	32	40		227	207.9	190	60				52	260-425	4.1	10 000

Inch range

Technical Specification ISO form AD/B

Design	Taper	Part no.	Item description	Dimensions, inch														
				D1	D2	D3	D4	L1	L2	L3	L4	L5	depth	T* ft-lb	Weight kg	G 2.5 at rpm		
○ 1	40	683940-T	HG PENCIL-1/4"x50/ISO40	0.250	0.472	1.575		3.425	2.673	1.969					1.575	13-20	1	25 000
○ 1		684000-T	HG PENCIL-1/2"x50/ISO40	0.500	0.768	1.575		3.425	2.673	1.969					1.575	55-105	1.1	25 000
○ 1		684010-T	HG PENCIL-1/2"x100/ISO40	0.500	0.768	1.575		5.394	4.642	3.937					1.575	55-105	1.2	15 000
○ 2		684030-T	HG PENCIL-1/2"x150/ISO40	0.500	0.768	1.575	0.965	7.362	6.610	5.906	2.953	1.969			1.575	55-105	1.4	10 000
○ 3		684020-T	HG PENCIL-3/4"x110/ISO40	0.750	1.260	1.575		5.787	5.035	4.331	2.362				2.047	192-314	1.6	20 000
○ 3		684040-T	HG PENCIL-3/4"x190/ISO40	0.750	1.260	1.575		8.937	8.185	7.480	2.362				2.047	192-314	2.3	10 000
○ 1	50	684190-T	HG PENCIL 1/2"x50/ISO50	0.500	0.768	1.575		3.425	2.673	1.969					1.575	55-105	2.9	14 000
○ 1		684200-T	HG PENCIL 1/2"x100/ISO50	0.500	0.768	1.575		5.394	4.642	3.937					1.575	55-105	3	14 000
○ 2		684210-T	HG PENCIL 1/2"x150/ISO50	0.500	0.768	1.575	0.965	7.362	6.610	5.906	2.953	1.969			1.575	55-105	3.2	10 000
○ 3		684240-T	HG PENCIL 3/4"x110/ISO50	0.750	1.260	1.575		5.787	5.035	4.331	2.362				2.047	192-314	3.4	14 000
○ 3		684250-T	HG PENCIL 3/4"x190/ISO50	0.750	1.260	1.575		8.937	8.185	7.480	2.362				2.047	192-314	4.1	10 000

*) T = Min. and Max. transmittable torque using a h6 cylindrical tool, full depth insert. For additional information see section Technical Information.

- From stock
- On request

Information:

- Runout accuracy ≤ 0.004 mm at $2.5 \times D1$ (max. 50 mm)
 ≤ 0.00016 inch at $2.5 \times D1$ (max. 1.969 inch)
- ≤ 0.007 mm at $2.5 \times D1$ at length $L1 > 125$ mm
 ≤ 0.00028 inch at $2.5 \times D1$ at length $L1 > 4.921$ inch
- Tool shank h6 or h7 can be used
- Coolant through on all holders
- Bore for data carrier

Accessories:

Use preset Torque Wrench, 6 Nm, to ensure correct mounting of tools. Part no. 19050

ETP HYDRO-GRIP PENCIL can be used with reducing sleeves.

For additional information see section Accessories.



ETP HYDRO-GRIP® S

ISO Form AD - 7388-1

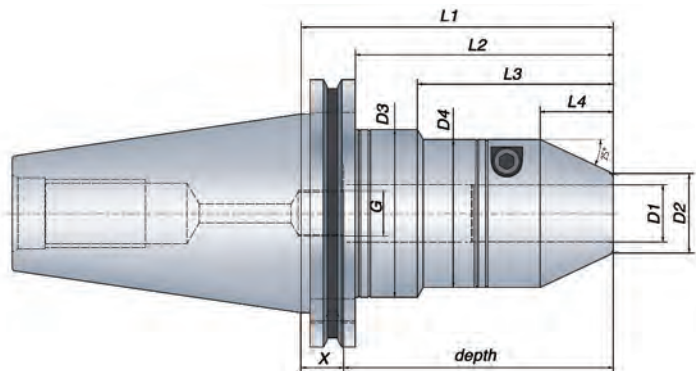

Metric range

Technical Specification ISO form AD

Taper	Part no.	Item description	Dimensions, mm											T* Nm	Weight kg	
			D1	D2	D3	D4	L1	L2	L3	L4	depth	G	X			
●	50	703763	ETP HG S-12x110/ISO50	12	21.5	59	43.5	110	90.9	69	23.6	50	M8x1	60	60-125	3.7
●		704378	ETP HG S-20x110/ISO50	20	28	59	52	110	90.9	69	25.7	95	M16x1	15	260-425	3.8
●		703764	ETP HG S-32x110/ISO50	32	40	69.5		110	90.9		31.6	95	M16x1	15	820-1250	4.3

Inch range

Technical Specification ISO form AD

Taper	Part no.	Item description	Dimensions, inch											T* ft-lb	Weight kg	
			D1	D2	D3	D4	L1	L2	L3	L4	depth	G	X			
●	50	703763-T	ETP HG S-1/2"x110/ISO50	0.500	0.846	2.323	1.713	4.331	3.579	2.717	0.929	1.969	M8x1	2.362	55-105	3.7
●		704378-T	ETP HG S-3/4"x110/ISO50	0.750	1.102	2.323	2.047	4.331	3.579	2.717	1.012	3.740	M16x1	0.591	192-314	3.8

*) T = Min. and Max. transmittable torque using a h6 cylindrical tool, full depth insert. For additional information see section Technical Information.

- From stock
- On request

Information:

- Runout accuracy ≤ 0.004 mm at $2.5 \times D1$ (max. 50 mm), ≤ 0.00016 inch at $2.5 \times D1$ (max. 1.969 inch)
- Tool shank h6 or h7 can be used
- Coolant through on all holders
- Bore for data carrier

Accessories:

Use preset Torque Wrench, 6 Nm, to ensure correct mounting of tools. Part no. 19050.

ETP HYDRO-GRIP S can be used with reducing sleeves.

For additional information see section Accessories.



ETP ECOGRIP™

ISO Form AD/B - 7388-1

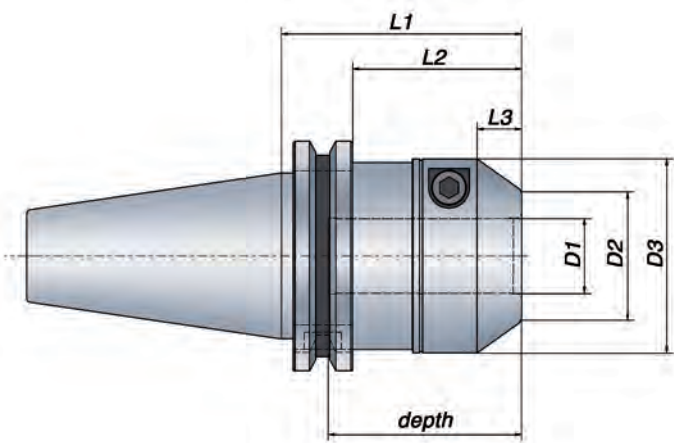

Technical Specification ISO form AD/B													
Taper	Part no.	Item description	Dimensions, mm										
			D1	D2	D3	L1	L2	L3	depth	T* Nm	Weight kg	G 2.5 at rpm	
40	687580	ECOGRIP-20/ISO40	20	35	52	64.5	45.4	12	52	400-535	1.3	25 000	

*) T = Min. and Max. transmittable torque using a h6 cylindrical tool, full depth insert. For additional information see section Technical Information.

- From stock
- On request

Information:

- Runout accuracy ≤ 0.004 mm at $2.5 \times D1$ (max. 50 mm)
- ≤ 0.00016 inch at $2.5 \times D1$ (max. 1.969 inch)
- Tool shank h6 or h7 can be used
- Center thread, M8x1.25, for axial length adjustment screw (screw not included)
- Coolant through on all holders
- Bore for data carrier

Accessories:

Use preset Torque Wrench, 10 Nm, to ensure correct mounting of tools. Part no. 19052.

ETP ECOGRIP can be used with reducing sleeves. For additional information see section Accessories.



ETP HYDRO-GRIP®

BT Form AD - JIS B 6339

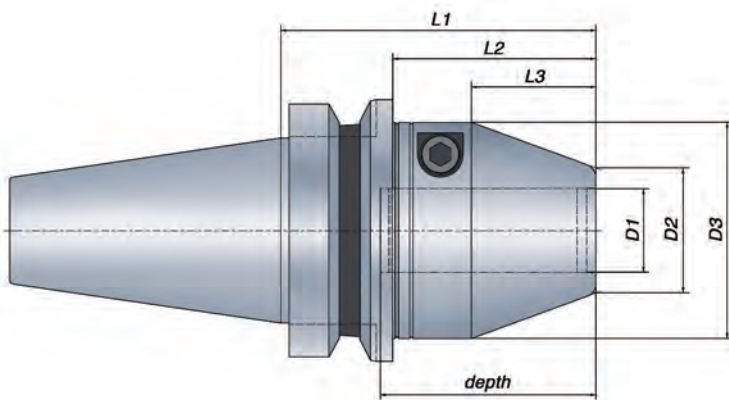

Metric range

Technical Specification BT form AD

Taper	Part no.	Item description	Dimensions, mm										
			D1	D2	D3	L1	L2	L3	depth	T* Nm	Weight kg	G 2.5 at rpm	
●	30	685970	HG-12/BT30	12	22	43.5	59	37	18	40	60-125	0.7	25 000
○		685980	HG-16/BT30	16	26	48	69	47	28	50	165-270	1	25 000
●		685991	HG-20/BT30	20	30	52	89	54	30	52	260-425	1.1	25 000

Inch range

Technical Specification BT form AD

Taper	Part no.	Item description	Dimensions, inch										
			D1	D2	D3	L1	L2	L3	depth	T* ft·lb	Weight kg	G 2.5 at rpm	
●	30	685970-T	HG-1/2"/BT30	0.500	0.866	1.713	2.323	1.457	0.709	1.575	55-105	0.7	25 000
●		685991-T	HG-3/4"/BT30	0.750	1.181	2.047	3.504	2.126	1.181	2.047	192-314	1.1	25 000

*) T = Min. and Max. transmittable torque using a h6 cylindrical tool, full depth insert. For additional information see section Technical Information.

- From stock
- On request

Information:

- Runout accuracy < 0.004 mm at 2.5 x D1 (max. 50 mm) ≤ 0.00016 inch at 2.5x D1 (max. 1.969 inch)
- Tool shank h6 or h7 can be used
- Center thread, M8x1.25, for axial length adjustment screw (screw not included)
- Coolant through on all holders
- Bore for data carrier - available on request

Accessories:

Use preset Torque Wrench, 6 Nm, to ensure correct mounting of tools. Part no. 19050

ETP HYDRO-GRIP can be used with reducing sleeves. For additional information see section Accessories.



ETP HYDRO-GRIP®

BT Form AD/B - JIS B 6339

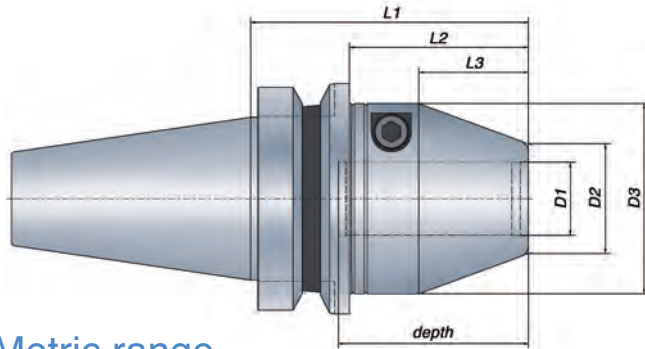

Metric range

Technical Specification <i>BT form AD/B</i>													
Taper	Part no.	Item description	Dimensions, mm										
			D1	D2	D3	L1	L2	L3	depth	T* Nm	Weight kg	G 2.5 at rpm	
●	40	685000	HG-12/BT40	12	22	43.5	64	37	18	40	60-125	1.3	25 000
●		685010	HG-12x100/BT40	12	22	43.5	100	73	18	40	60-125	1.7	25 000
○		685020	HG-16/BT40	16	26	48	74	47	28	50	165-270	1.4	25 000
○		685030	HG-16x125/BT40	16	26	48	125	98	28	50	165-270	1.9	25 000
●		685040	HG-20/BT40	20	30	52	76	49	30	52	260-425	1.5	25 000
●		685050	HG-20x125/BT40	20	30	52	125	98	30	52	260-425	2.3	25 000
●		685060	HG-25/BT40	25	35	59	80	53	34	56	480-710	1.6	25 000
○	50	685070	HG-12/BT50	12	22	43.5	75	37	18	40	60-125	3.9	14 000
○		685080	HG-12x100/BT50	12	22	43.5	100	62	18	40	60-125	4.3	14 000
○		685090	HG-16/BT50	16	26	48	85	47	28	50	165-270	4.1	14 000
○		685100	HG-16x125/BT50	16	26	48	125	87	28	50	165-270	4.6	14 000
●		685110	HG-20/BT50	20	30	52	87	49	30	52	260-425	4.1	14 000
●		685120	HG-20x150/BT50	20	30	52	150	112	30	52	260-425	5.2	14 000
●		685130	HG-25/BT50	25	35	59	91	53	34	56	480-710	4.3	14 000
●		685140	HG-25x150/BT50	25	35	59	150	112	34	56	480-710	5.5	14 000
●		685150	HG-32/BT50	32	42	69.5	95	57	38	60	820-1250	4.5	14 000

Inch range

Technical Specification <i>BT form AD/B</i>													
Taper	Part no.	Item description	Dimensions, inch										
			D1	D2	D3	L1	L2	L3	depth	T* ft-lb	Weight kg	G 2.5 at rpm	
○	40	685000-T	HG-1/2"/BT40	0.500	0.866	1.713	2.520	1.457	0.709	1.575	55-105	1.3	25 000
○		685010-T	HG-1/2"x100/BT40	0.500	0.866	1.713	3.937	2.874	0.709	1.575	55-105	1.7	25 000
○		685040-T	HG-3/4"/BT40	0.750	1.181	2.047	2.992	1.929	1.181	2.047	192-314	1.5	25 000
○		685050-T	HG-3/4"x125/BT40	0.750	1.181	2.047	4.921	3.858	1.181	2.047	192-314	2.3	25 000
○		685060-T	HG-1"/BT40	1.000	1.378	2.323	3.150	2.087	1.339	2.205	354-524	1.6	25 000
○	50	685110-T	HG-3/4"/BT50	0.750	1.181	2.047	3.425	1.929	1.181	2.047	192-314	4.1	14 000
○		685120-T	HG-3/4"x150/BT50	0.750	1.181	2.047	5.906	4.409	1.181	2.047	192-314	5.2	14 000
○		685130-T	HG-1"/BT50	1.000	1.378	2.323	3.583	2.087	1.339	2.205	354-524	4.3	14 000
○		685140-T	HG-1"x150/BT50	1.000	1.378	2.323	5.906	4.409	1.339	2.205	354-524	5.5	14 000
○		685150-T	HG-1 1/4"/BT50	1.250	1.654	2.736	3.740	2.244	1.496	2.362	605-922	4.5	14 000

*) T = Min. and Max. transmittable torque using a h6 cylindrical tool, full depth insert. For additional information see section Technical Information.

- From stock
- On request

Information:

- Runout accuracy ≤ 0.004 mm at 2.5 x D1 (max. 50 mm), ≤ 0.00016 inch at 2.5x D1 (max. 1.969 inch)
- Tool shank h6 or h7 can be used
- Center thread, M8x1.25, for axial length adjustment screw (screw not included)
- Coolant thread on all holders
- Bore for data carrier

Accessories:

Use preset Torque Wrench, 6 Nm, to ensure correct mounting of tools. Part no. 19050.

ETP HYDRO-GRIP can be used with reducing sleeves. For additional information see section Accessories.



ETP HYDRO-GRIP® HD

BT Form AD - JIS B 6339

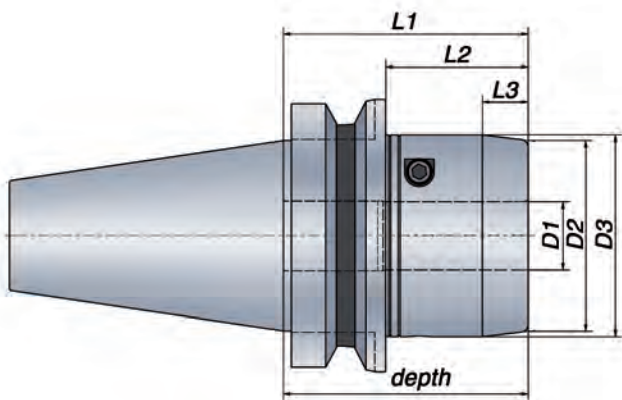

Metric range

Technical Specification BT form AD

Taper	Part no.	Item description	Dimensions, mm											
			D1	D2	D3	L1	L2	L3	depth	T* Nm	Weight kg	G 2.5 at rpm		
●	40	682000	HG HD-20/BT40	20	59	63	79			17	79	400-535	2	25 000
●	50	682010	HG HD-20/BT50	20	59	63	87	49	17	87	400-535	4.5	25 000	
●		682020	HG HD-25/BT50	25	70	74	91	53	17	91	740-940	5	14 000	
●		682030	HG HD-32/BT50	32	76	80	95	57	17	95	1325-1670	5.2	14 000	

Inch range

Technical Specification BT form AD

Taper	Part no.	Item description	Dimensions, inch											
			D1	D2	D3	L1	L2	L3	depth	T* ft·lb	Weight kg	G 2.5 at rpm		
○	40	682000-T	HG HD-3/4"/BT40	0.750	2.323	2.480	3.110			0.669	3.110	295-395	2	25 000
○	50	682010-T	HG HD-3/4"/BT50	0.750	2.323	2.480	3.425	1.929	0.669	3.425	295-395	4.5	25 000	
○		682020-T	HG HD-1"/BT50	1.000	2.756	2.913	3.583	2.087	0.669	3.583	546-693	5	25 000	
○		682030-T	HG HD-1 1/4"/BT50	1.250	2.992	3.150	3.740	2.244	0.669	3.740	977-1232	5.2	25 000	

*) T = Min. and Max. transmittable torque using a h6 cylindrical tool, full depth insert. For additional information see section Technical Information.

- From stock
- On request

Information:

- Runout accuracy ≤ 0.004 mm at $2.5 \times D1$ (max. 50 mm),
 ≤ 0.00016 inch at $2.5 \times D1$ (max. 1.969 inch)
- Tool shank h6 or h7 can be used
- Center thread, M12x1, for axial length adjustment screw (screw not included)
- Coolant through on all holders
- Bore for data carrier - available on request

Accessories:

Use preset Torque Wrench, 10 Nm, to ensure correct mounting of tools. Part no. 19052.

ETP HYDRO-GRIP HD can be used with reducing sleeves.
For additional information see section Accessories.



ETP HYDRO-GRIP® PENCIL BT Form AD - JIS B 6339

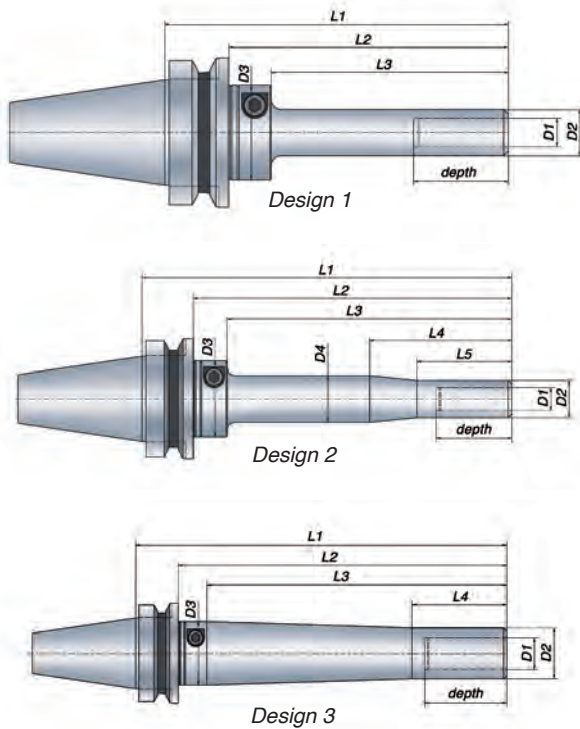

Metric range

Technical Specification <i>BT form AD</i>				Dimensions, mm												
Design	Taper	Part no.	Item description	D1	D2	D3	D4	L1	L2	L3	L4	L5	depth	T* Nm	Weight kg	G 2.5 at rpm
● 1	30	683000	HG PENCIL-6x50/BT30	6	12	40		90	68	50			40	12-22	0.6	25 000
○ 1		683010	HG PENCIL-8x50/BT30	8	14.5	40		90	68	50			40	27-40	0.6	25 000
○ 1		683030	HG PENCIL-10x50/BT30	10	17	40		90	68	50			40	35-70	0.6	25 000
○ 1		683020	HG PENCIL-10x100/BT30	10	17	40		140	118	100			40	35-70	0.7	15 000
● 1		683060	HG PENCIL-12x50/BT30	12	19.5	40		90	68	50			40	60-125	0.6	25 000
● 1		683040	HG PENCIL-12x100/BT30	12	19.5	40		140	118	100			40	60-125	0.7	15 000
● 2		683050	HG PENCIL-12x150/BT30	12	19.5	40	24.5	190	168	150	75	50	40	60-125	1	10 000
○ 3		684360	HG PENCIL-20x110/BT30	20	32	40		150	128	110	60		52	260-425	1.2	0 000
○ 3		684370	HG PENCIL-20x190/BT30	20	32	40		230	208	190	60		52	260-425	1.8	10 000

Inch range

Technical Specification <i>BT form AD</i>				Dimensions, inch												
Design	Taper	Part no.	Item description	D1	D2	D3	D4	L1	L2	L3	L4	L5	depth	T* ft-lb	Weight kg	G 2.5 at rpm
○ 1	30	683000-T	HG PENCIL-1/4"x50/BT30	0.250	0.472	1.575		3.543	2.677	1.969			1.575	13-20	0.6	25 000
● 1		683060-T	HG PENCIL-1/2"x50/BT30	0.500	0.768	1.575		3.543	2.677	1.969			1.575	55-105	0.6	25 000
● 1		683040-T	HG PENCIL-1/2"x100/BT30	0.500	0.768	1.575		5.512	4.646	3.937			1.575	55-105	0.7	15 000
○ 2		683050-T	HG PENCIL-1/2"x150/BT30	0.500	0.768	1.575	0.965	7.480	6.614	5.906	2.953	1.969	1.575	55-105	1	10 000

*) T = Min. and Max. transmittable torque using a h6 cylindrical tool, full depth insert. For additional information see section Technical Information.

- From stock
- On request

Information:

- Runout accuracy ≤ 0.004 mm at $2.5 \times D1$ (max. 50 mm), ≤ 0.00016 inch at $2.5 \times D1$ (max. 1.969 inch)
- ≤ 0.007 mm at $2.5 \times D1$ at length $L1 > 125$ mm
- ≤ 0.00028 inch at $2.5 \times D1$ at length $L1 > 4.921$ inch
- Tool shank h6 or h7 can be used
- Coolant through on all holders
- Bore for data carrier - available on request

Accessories:

Use preset Torque Wrench, 6 Nm, to ensure correct mounting of tools. Part no. 19050.

ETP HYDRO-GRIP PENCIL can be used with reducing sleeves. For additional information see section Accessories.



ETP HYDRO-GRIP® PENCIL BT Form AD/B - JIS B 6339

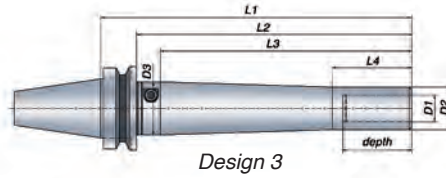
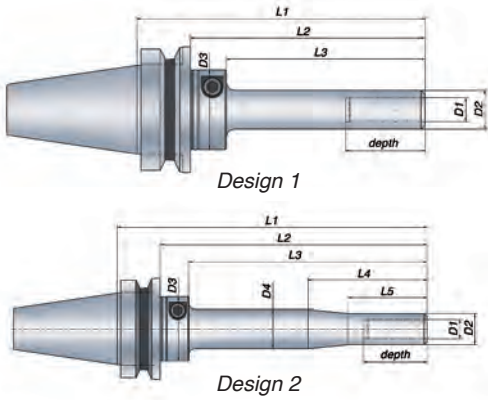

Metric range

Technical Specification BT form AD/B				Dimensions, mm													
Design	Taper	Part no.	Item description	D1	D2	D3	D4	L1	L2	L3	L4	L5	depth	T* Nm	Weight kg	G 2.5 at rpm	
●	1	40	683070	HG PENCIL-6x50/BT40	6	12	40		95	68	50			40	12-22	1.2	25 000
○	1		683080	HG PENCIL-8x50/BT40	8	14.5	40		95	68	50			40	27-40	1.2	25 000
○	1		683100	HG PENCIL-10x50/BT40	10	17	40		95	68	50			40	35-70	1.2	25 000
○	1		683090	HG PENCIL-10x100/BT40	10	17	40		145	118	100			40	35-70	1.3	15 000
●	1		683160	HG PENCIL-12x50/BT40	12	19.5	40		95	68	50			40	60-125	1.2	25 000
●	1		683170	HG PENCIL-12x100/BT40	12	19.5	40		145	118	100			40	60-125	1.3	15 000
●	2		683110	HG PENCIL-12x150/BT40	12	19.5	40	24.5	195	168	150	75	50	40	60-125	1.6	0 000
○	1		683130	HG PENCIL-16x75/BT40	16	26	40		120	93	75			50	165-270	1.4	15 000
○	1		683120	HG PENCIL-16x125/BT40	16	26	40		170	143	125			50	165-270	1.6	10 000
●	3		683150	HG PENCIL-20x110/BT40	20	32	40		155	128	110	60		52	260-425	1.8	20 000
●	3		683140	HG PENCIL-20x190/BT40	20	32	40		235	208	190	60		52	260-425	2.4	10 000
●	1	50	684090	HG PENCIL 12x50/BT50	12	19.5	40		106	68	50			40	60-110	3.8	14 000
●	1		684100	HG PENCIL 12x100/BT50	12	19.5	40		156	118	100			40	60-110	3.9	14 000
●	2		684110	HG PENCIL 12x150/BT50	12	19.5	40	24.5	206	168	150	75	50	40	60-110	4.2	10 000
●	3		684140	HG PENCIL 20x110/BT50	20	32	40		166	128	110	60		52	260-425	4.4	14 000
●	3		684150	HG PENCIL 20x190/BT50	20	32	40		246	206.5	190	60		52	260-425	5	10 000

Inch range

Technical Specification BT form AD/B				Dimensions, inch													
Design	Taper	Part no.	Item description	D1	D2	D3	D4	L1	L2	L3	L4	L5	depth	T* ft-lb	Weight kg	G 2.5 at rpm	
○	1	40	683070-T	HG PENCIL-1/4"x50/BT40	0.250	0.472	1.575		3.740	2.677	1.969			1.575	13-20	1.2	25 000
○	1		683160-T	HG PENCIL-1/2"x50/BT40	0.500	0.768	1.575		3.740	2.677	1.969			1.575	55-105	1.2	25 000
○	1		683170-T	HG PENCIL-1/2"x100/BT40	0.500	0.768	1.575		5.709	4.646	3.937			1.575	55-105	1.3	15 000
○	2		683110-T	HG PENCIL-1/2"x150/BT40	0.500	0.768	1.575	0.965	7.677	6.614	5.906	2.953	1.969	1.575	55-105	1.6	10 000
○	3		683150-T	HG PENCIL-3/4"x110/BT40	0.750	1.260	1.575		6.102	5.039	4.331	2.362		2.047	192-314	1.8	20 000
○	3		683140-T	HG PENCIL-3/4"x190/BT40	0.750	1.260	1.575		9.252	8.189	7.480	2.362		2.047	192-314	2.4	10 000
○	1	50	684090-T	HG PENCIL 1/2"x50/BT50	0.500	0.768	1.575		4.173	2.677	1.969			1.575	55-105	3.8	14 000
○	1		684100-T	HG PENCIL 1/2"x100/BT50	0.500	0.768	1.575		6.142	4.646	3.937			1.575	55-105	3.9	14 000
○	2		684110-T	HG PENCIL 1/2"x150/BT50	0.500	0.768	1.575	0.965	8.110	6.614	5.906	2.953	1.969	1.575	55-105	4.2	10 000
○	3		684140-T	HG PENCIL 3/4"x110/BT50	0.750	1.260	1.575		6.535	5.039	4.331	2.362		2.047	192-314	4.4	14 000
○	3		684150-T	HG PENCIL 3/4"x190/BT50	0.750	1.260	1.575		9.685	8.130	7.480	2.362		2.047	192-314	5	10 000

*) T = Min. and Max. transmittable torque using a h6 cylindrical tool, full depth insert. For additional information see section Technical Information.

- From stock
- On request

Information:

- Runout accuracy ≤ 0.004 mm at 2.5 x D1 (max. 50 mm), ≤ 0.00016 inch at 2.5x D1 (max. 1.969 inch)
- ≤ 0.007 mm at 2.5 x D1 at length L1 > 125 mm
- ≤ 0.00028 inch at 2.5x D1 at length L1 > 4.921 inch
- Tool shank h6 or h7 can be used
- Coolant through on all holders
- Bore for data carrier - available on request

Accessories:

Use preset Torque Wrench, 6 Nm, to ensure correct mounting of tools. Part no. 19050.

ETP HYDRO-GRIPPENCIL can be used with reducing sleeves.

For additional information see section Accessories.



ETP ECOGRIP™

BT Form AD/B - JIS B 6339

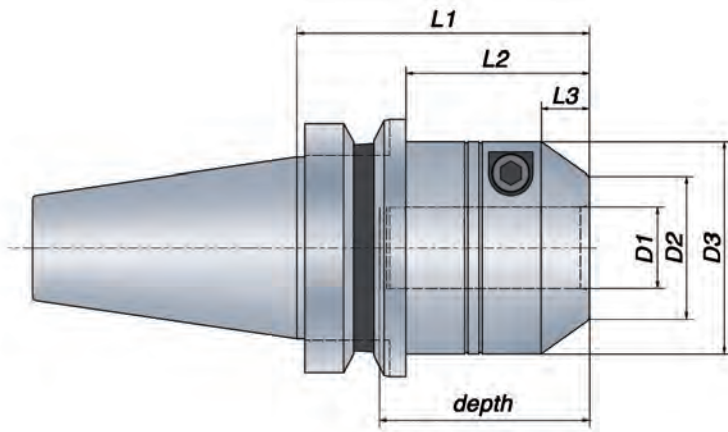

Metric range

Technical Specification <i>BT form AD/B</i>			Dimensions, mm										
Taper	Part no.	Item description	D1	D2	D3	L1	L2	L3	depth	T* Nm	Weight kg	G 2.5 at rpm	
● 40	687530	ECOGRIP-20/BT40	20	35	52	72.5	45.5	12	52	400-535	1.5	25 000	

*) T = Min. and Max. transmittable torque using a h6 cylindrical tool, full depth insert. For additional information see section Technical Information.

- From stock
- On request

Information:

- Runout accuracy ≤ 0.004 mm at $2.5 \times D1$ (max. 50 mm), ≤ 0.00016 inch at $2.5 \times D1$ (max. 1.969 inch)
- Tool shank h6 or h7 can be used
- Center thread, M8x1.25, for axial length adjustment screw (screw not included)
- Coolant through on all holders
- Bore for data carrier - available on request

Accessories:

Use preset Torque Wrench, 10 Nm, to ensure correct mounting of tools. Part no. 19052.

ETP ECOGRIP can be used with reducing sleeves. For additional information see section Accessories.



ETP HYDRO-GRIP®

CAT Form AD/B - ASME B5.50

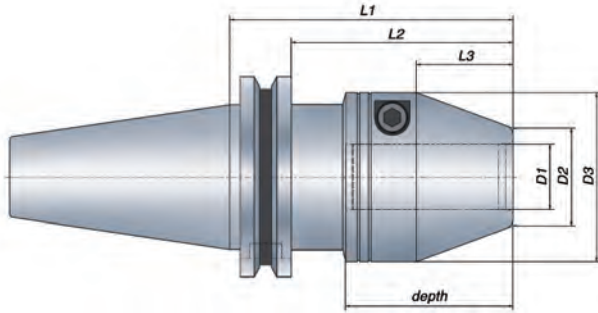

Metric range

Technical Specification CAT form AD/B

Taper	Part no.	Item description	Dimensions, mm									T* Nm	Weight kg	G 2.5 at rpm
			D1	D2	D3	L1	L2	L3	depth					
●	40	685470	HG-12/CAT40	12	22	43.5	56	36.95	18	40	60-125	1.1	25 000	
●		685480	HG-12x100/CAT40	12	22	43.5	100	80.95	18	40	60-125	1.6	25 000	
○		685490	HG-16/CAT40	16	26	48	86	66.95	28	50	165-270	1.5	25 000	
○		685500	HG-16x125/CAT40	16	26	48	125	105.95	28	50	165-270	2	25 000	
●		685510	HG-20/CAT40	20	30	52	88	68.95	30	52	260-425	1.5	25 000	
●		685520	HG-20x125/CAT40	20	30	52	125	105.95	30	52	260-425	2.1	25 000	
●		685530	HG-25/CAT40	25	35	59	93	73.95	34	56	480-710	1.7	25 000	
○	50	685540	HG-12/CAT50	12	22	43.5	56	36.95	18	40	60-125	2.8	14 000	
○		685550	HG-12x100/CAT50	12	22	43.5	100	80.95	18	40	60-125	3.2	14 000	
○		685560	HG-16/CAT50	16	26	48	66	46.95	28	50	165-270	3	14 000	
○		685570	HG-16x125/CAT50	16	26	48	125	105.95	28	50	165-270	3.5	14 000	
●		685580	HG-20/CAT50	20	30	52	68	48.95	30	52	260-425	3	14 000	
●		685590	HG-20x150/CAT50	20	30	52	150	130.95	30	52	260-425	4.4	14 000	
●		685600	HG-25/CAT50	25	35	59	72	52.95	34	56	480-710	3.2	14 000	
●		685610	HG-25x150/CAT50	25	35	59	150	130.95	34	56	480-710	4.8	14 000	
●		685620	HG-32/CAT50	32	42	69.5	77	57.95	38	60	820-1250	3.5	14 000	

Inch range

Technical Specification CAT form AD/B

Taper	Part no.	Item description	Dimensions, inch									T* ft-lb	Weight kg	G 2.5 at rpm
			D1	D2	D3	L1	L2	L3	depth					
●	40	685470-T	HG-1/2"/CAT40	0.500	0.866	1.713	2.205	1.455	0.709	1.575	55-105	1.1	25 000	
○		685480-T	HG-1/2"x100/CAT40	0.500	0.866	1.713	3.937	3.187	0.709	1.575	55-105	1.6	25 000	
●		685510-T	HG-3/4"/CAT40	0.750	1.181	2.047	3.465	2.715	1.181	2.047	192-314	1.5	25 000	
●		682410-T	HG-3/4"x4"/CAT40	0.750	1.181	2.047	4.000	3.250	1.181	2.047	192-314	2.1	25 000	
●		685520-T	HG-3/4"x125/CAT40	0.750	1.181	2.047	4.921	4.171	1.181	2.047	192-314	2.1	25 000	
●		682420-T	HG-3/4"x6"/CAT40	0.750	1.181	2.047	6.000	5.250	1.181	2.047	192-314	2.6	25 000	
●		685530-T	HG-1"/CAT40	1.000	1.378	2.323	3.661	2.911	1.339	2.205	354-524	1.7	25 000	
●	50	685580-T	HG-3/4"/CAT50	0.750	1.181	2.047	2.677	1.927	1.181	2.047	192-314	3	14 000	
●		682460-T	HG-3/4"x4"/CAT50	0.750	1.181	2.047	4.000	3.250	1.181	2.047	192-314	3.6	14 000	
●		682470-T	HG-3/4"x6"/CAT50	0.750	1.181	2.047	6.000	5.250	1.181	2.047	192-314	4.4	14 000	
●		685600-T	HG-1"/CAT50	1.000	1.378	2.323	2.835	2.085	1.339	2.205	354-524	3.2	14 000	
●		682480-T	HG-1"x4"/CAT50	1.000	1.378	2.323	4.000	3.250	1.339	2.205	354-524	3.8	14 000	
●		682490-T	HG-1"x6"/CAT50	1.000	1.378	2.323	6.000	5.250	1.339	2.205	354-524	4.9	14 000	
●		685620-T	HG-1 1/4"/CAT50	1.250	1.654	2.736	3.031	2.281	1.496	2.362	605-922	3.5	14 000	

*) T = Min. and Max. transmittable torque using a h6 cylindrical tool, full depth insert. For additional information see section Technical Information.

For ISO equivalents, please contact ETP customer service; sales@etpinc.com

● From stock

○ On request

Information:

- Runout accuracy ≤ 0.004 mm at $2.5 \times D1$ (max. 50 mm), ≤ 0.00016 inch at $2.5 \times D1$ (max. 1.969 inch)
- Tool shank h6 or h7 can be used
- Center thread, M8x1.25, for axial length adjustment screw (screw not included)
- Coolant through on all holders
- Bore for data carrier

Accessories:

Use preset Torque Wrench, 6 Nm, to ensure correct mounting of tools. Part no. 19050.

ETP HYDRO-GRIP can be used with reducing sleeves.

For additional information see section Accessories.



ETP HYDRO-GRIP®

CAT Form AD/B - ASME B5.50 Dual Contact

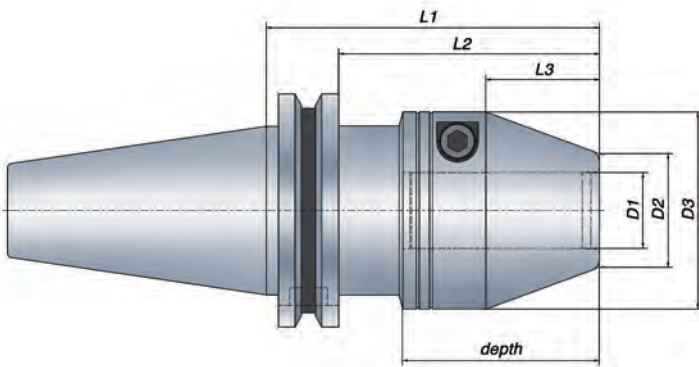

Metric range

Technical Specification CAT form AD/B Dual Contact

Dimensions, mm

Taper	Part no.	Item description	D1	D2	D3	L1	L2	L3	depth	T* Nm	Weight kg	G 2.5 at rpm
40	681480	HG-20/DC-CAT40	20	30	52	88	68.95	30	52	260 - 425	1.5	25 000

*) T = Min. and Max. transmittable torque using a h6 cylindrical tool, full depth insert. For additional information see section Technical Information.

Inch range

Technical Specification CAT form AD/B Dual Contact

Dimensions, inch

Taper	Part no.	Item description	D1	D2	D3	L1	L2	L3	depth	T* ft·lb	Weight kg	G 2.5 at rpm
40	681480-T	HG-3/4"/DC-CAT40	0.750	1.181	2.047	3.465	2.715	1.181	2.047	192 - 314	1.5	25 000

*) T = Min. and Max. transmittable torque using a h6 cylindrical tool, full depth insert. For additional information see section Technical Information.

- From stock
- On request

Information:

- Runout accuracy ≤ 0.004 mm at $2.5 \times D1$ (max. 50 mm), ≤ 0.00016 inch at $2.5 \times D1$ (max. 1.969 inch)
- Tool shank h6 or h7 can be used
- Center thread, M8x1.25, for axial length adjustment screw (screw not included)
- Coolant through on all holders
- Bore for data carrier

Accessories:

Use preset Torque Wrench, 6 Nm, to ensure correct mounting of tools. Part no. 19050.

ETP HYDRO-GRIP can be used with reducing sleeves. For additional information see section Accessories.



ETP HYDRO-GRIP® HD

CAT Form AD/B - ASME B5.50

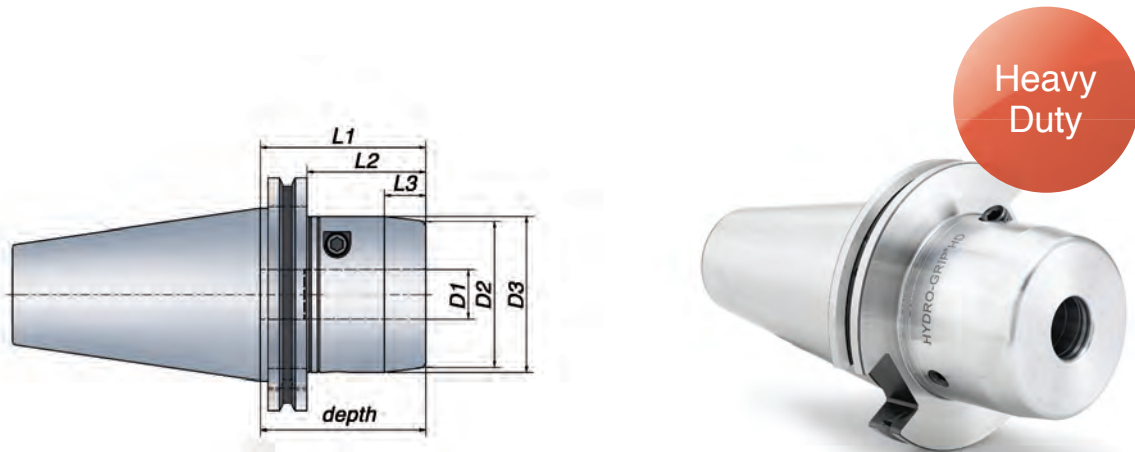

Metric range

Technical Specification CAT form AD/B

Taper	Part no.	Item description	Dimensions, mm										
			D1	D2	D3	L1	L2	L3	depth	T* Nm	Weight kg	G 2.5 at rpm	
● 40	682110	HG HD-20/CAT40	20	59	63	90	70.95	17	90	400-535	2	25 000	
● 50	682120	HG HD-20/CAT50	20	59	63	68	48.95	17	68	400-535	3.6	14 000	
●	682130	HG HD-25/CAT50	25	70	74	92	72.95	17	92	740-940	4.6	14 000	
●	682140	HG HD-32/CAT50	32	76	80	97	77.95	17	97	1325-1670	4.8	14 000	

Inch range

Technical Specification CAT form AD/B

Taper	Part no.	Item description	Dimensions, inch										
			D1	D2	D3	L1	L2	L3	depth	T* ft-lb	Weight kg	G 2.5 at rpm	
● 40	682110-T	HG HD-3/4"/CAT40	0.750	2.323	2.480	3.543	2.793	0.669	3.543	295-395	2	25 000	
● 50	682120-T	HG HD-3/4"/CAT50	0.750	2.323	2.480	2.677	1.927	0.669	2.677	295-395	3.6	14 000	
●	682130-T	HG HD-1"/CAT50	1.000	2.756	2.913	3.622	2.872	0.669	3.622	546-693	4.6	14 000	
●	682140-T	HG HD-1 1/4"/CAT50	1.250	2.992	3.150	3.819	3.069	0.669	3.819	977-1232	4.8	14 000	

*) T = Min. and Max. transmittable torque using a h6 cylindrical tool, full depth insert. For additional information see section Technical Information.

For ISO equivalents, please contact ETP customer service; sales@etpinc.com

● From stock

○ On request

Information:

- Runout accuracy ≤ 0.004 mm at $2.5 \times D1$ (max. 50 mm), ≤ 0.00016 inch at $2.5 \times D1$ (max. 1.969 inch)
- Tool shank h6 or h7 can be used
- Center thread, M12x1, for axial length adjustment screw (screw not included)
- Coolant through on all holders
- Bore for data carrier - available on request

Accessories:

Use preset Torque Wrench, 10 Nm, to ensure correct mounting of tools. Part no. 19052.

ETP HYDRO-GRIP HD can be used with reducing sleeves. For additional information see section Accessories.



ETP HYDRO-GRIP® HD

CAT Form AD/B - ASME B5.50 Dual Contact

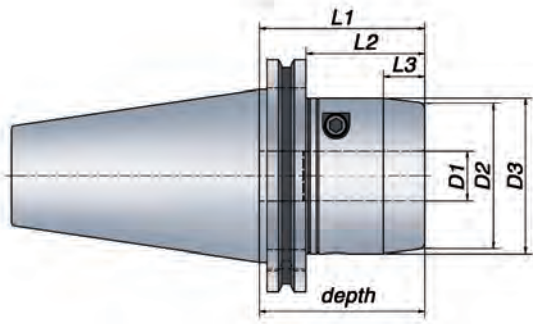

Metric range

Technical Specification CAT form AD/B Dual Contact

Taper	Part no.	Item description	Dimensions, mm										
			D1	D2	D3	L1	L2	L3	depth	T* Nm	Weight kg	G 2.5 at rpm	
40	682350	HG HD-20/DC-CAT40	20	59	63	90	70.95	17	90	400-535	2	25 000	

*) T = Min. and Max. transmittable torque using a h6 cylindrical tool, full depth insert. For additional information see section Technical Information.

Inch range

Technical Specification CAT form AD/B Dual Contact

Taper	Part no.	Item description	Dimensions, inch										
			D1	D2	D3	L1	L2	L3	depth	T* ft·lb	Weight kg	G 2.5 at rpm	
40	682350-T	HG HD-3/4"/DC-CAT40	0.750	2.323	2.480	3.543	2.793	0.669	3.543	295-395	2	25 000	

*) T = Min. and Max. transmittable torque using a h6 cylindrical tool, full depth insert. For additional information see section Technical Information.

For ISO equivalents, please contact ETP customer service; sales@etpinc.com

- From stock
- On request

Information:

- Runout accuracy ≤ 0.004 mm at $2.5 \times D1$ (max. 50 mm), ≤ 0.00016 inch at $2.5 \times D1$ (max. 1.969 inch)
- Tool shank h6 or h7 can be used
- Center thread, M12x1, for axial length adjustment screw (screw not included)
- Coolant through on all holders
- Bore for data carrier - available on request

Accessories:

Use preset Torque Wrench, 10 Nm, to ensure correct mounting of tools. Part no. 19052.

ETP HYDRO-GRIP HD can be used with reducing sleeves. For additional information see section Accessories.



ETP HYDRO-GRIP® G2 SLENDER CAT Form AD/B - ASME B5.50

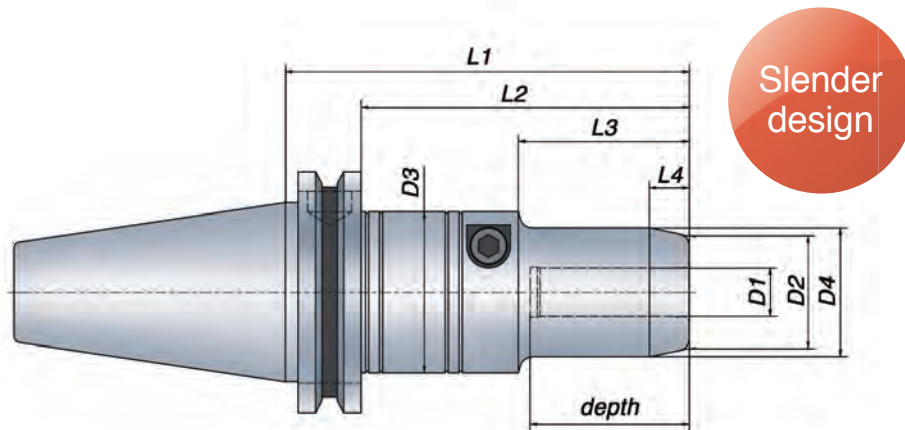

Metric range

Technical Specification CAT form AD/B

Taper	Part no.	Item description	Dimensions, mm				inch		mm			T* Nm	Weight kg	G 2.5 at rpm	
			D1	D2	D3	D4	L1	L2	L3	L4	depth				
○	40	681600	HG G2 SLENDER-12x4"/CAT40	12	28	40	32	101.6	3.250	43	10	40	60-125	1.4	25 000
○		681610	HG G2 SLENDER-12x6"/CAT40	12	28	40	32	152.4	5.250	43	10	40	60-125	1.9	25 000
○		681620	HG G2 SLENDER-16x4"/CAT40	16	34	40	38	101.6	3.250	43	10	40	165-270	1.5	25 000
○		681630	HG G2 SLENDER-16x6"/CAT40	16	34	40	38	152.4	5.250	43	10	40	165-270	2	25 000

Inch range

Technical Specification CAT form AD/B

Taper	Part no.	Item description	Dimensions, inch											T* ft-lb	Weight kg	G 2.5 at rpm
			D1	D2	D3	D4	L1	L2	L3	L4	depth					
●	40	681600-T	HG G2 SLENDER-1/2"x4"/CAT40	0.500	1.102	1.575	1.260	4.000	3.250	1.693	0.393	1.575	55-105	1.4	25 000	
●		681610-T	HG G2 SLENDER-1/2"x6"/CAT40	0.500	1.102	1.575	1.260	6.000	5.250	1.693	0.393	1.575	55-105	1.9	25 000	
○		681620-T	HG G2 SLENDER-5/8"x4"/CAT40	0.625	1.339	1.575	1.496	4.000	3.250	1.693	0.393	1.575	122-199	1.5	25 000	
○		681630-T	HG G2 SLENDER-5/8"x6"/CAT40	0.625	1.339	1.575	1.496	6.000	5.250	1.693	0.393	1.575	122-199	2	25 000	
○	50	681740-T	HG G2 SLENDER-3/4"x4"/CAT50	0.750	1.417	1.969	1.575	4.000	3.250	2.165	0.393	2.047	192-314	3.4	25 000	
○		681750-T	HG G2 SLENDER-3/4"x6"/CAT50	0.750	1.417	1.969	1.575	6.000	5.250	2.165	0.393	2.047	192-314	4.1	25 000	

*) T = Min. and Max. transmittable torque using a h6 cylindrical tool, full depth insert. For additional information see section Technical Information.

● From stock

○ On request

Information:

- Runout accuracy ≤ 0.004 mm at $2.5 \times D1$ (max. 50 mm),
 ≤ 0.00016 inch at $2.5 \times D1$ (max. 1.969 inch)
- Tool shank h6 or h7 can be used

Accessories:

Use preset Torque Wrench, 6 Nm, to ensure correct mounting of tools. Part no. 19050.

ETP HYDRO-GRIP SLENDER can be used with reducing sleeves.

For additional information see section Accessories.



ETP HYDRO-GRIP® PENCIL

CAT Form AD/B - ASME B5.50

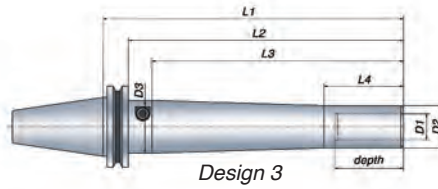
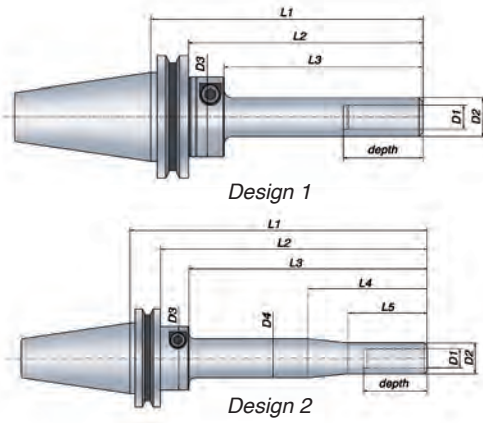

Metric range

Technical Specification CAT form AD/B				Dimensions, mm													
Design	Taper	Part no.	Item description	D1	D2	D3	D4	L1	L2	L3	L4	L5	depth	T* Nm	Weight kg	G 2.5 at rpm	
●	1	40	683560	HG PENCIL-6x50/CAT40	6	12	40		88	68.95	50			40	12-22	1	25 000
○	1		683570	HG PENCIL-8x50/CAT40	8	14.5	40		88	68.95	50			40	27-40	1	25 000
○	1		683590	HG PENCIL-10x50/CAT40	10	17	40		88	68.95	50			40	35-70	1	25 000
○	1		683580	HG PENCIL-10x100/CAT40	10	17	40		138	118.95	100			40	35-70	1.1	15 000
●	1		683650	HG PENCIL-12x50/CAT40	12	19.5	40		88	68.95	50			40	60-125	1	25 000
●	1		683600	HG PENCIL-12x100/CAT40	12	19.5	40		138	118.95	100			40	60-125	1.1	15 000
●	2		683610	HG PENCIL-12x150/CAT40	12	19.5	40	24.5	188	168.95	150	75	50	40	60-125	1.4	10 000
○	1		683630	HG PENCIL-16x75/CAT40	16	26	40		113	93.95	75			50	165-270	1.2	15 000
○	1		683620	HG PENCIL-16x125/CAT40	16	26	40		163	143.95	125			50	165-270	1.4	10 000
●	3		683660	HG PENCIL-20x110/CAT40	20	32	40		148	128.95	110	60		52	260-425	1.6	20 000
●	3		683640	HG PENCIL-20x190/CAT40	20	32	40		228	208.95	190	60		52	260-425	2.3	10 000
●	1	50	684290	HG PENCIL 12x50/CAT50	12	19.5	40		88	68.95	50			40	60-125	2.9	14 000
●	1		684300	HG PENCIL 12x100/CAT50	12	19.5	40		138	118.95	100			40	60-125	3	14 000
●	2		684310	HG PENCIL 12x150/CAT50	12	19.5	40	24.5	188	168.95	150	75	50	40	60-125	3.2	10 000
●	3		684340	HG PENCIL 20x110/CAT50	20	32	40		148	128.95	110	60		52	260-425	3.4	14 000
●	3		684350	HG PENCIL 20x190/CAT50	20	32	40		228	208.95	190	60		52	260-425	4.1	10 000

Inch range

Technical Specification CAT form AD/B				Dimensions, inch													
Design	Taper	Part no.	Item description	D1	D2	D3	D4	L1	L2	L3	L4	L5	depth	T* ft-lb	Weight kg	G 2.5 at rpm	
●	1	40	683560-T	HG PENCIL-1/4"x50/CAT40	0.250	0.472	1.575		3.465	2.715	1.969			1.575	13-20	1	25 000
●	1		683650-T	HG PENCIL-1/2"x50/CAT40	0.500	0.768	1.575		3.465	2.715	1.969			1.575	55-105	1	25 000
●	1		683600-T	HG PENCIL-1/2"x100/CAT40	0.500	0.768	1.575		5.433	4.683	3.937			1.575	55-105	1.1	15 000
●	2		683610-T	HG PENCIL-1/2"x150/CAT40	0.500	0.768	1.575	0.965	7.402	6.652	5.906	2.953	1.969	1.575	55-105	1.4	10 000
●	3		683660-T	HG PENCIL-3/4"x110/CAT40	0.750	1.260	1.575		5.827	5.077	4.331	2.362		2.047	192-314	1.6	20 000
●	3		683640-T	HG PENCIL-3/4"x190/CAT40	0.750	1.260	1.575		8.976	8.226	7.480	2.362		2.047	192-314	2.3	10 000
●	1	50	684290-T	HG PENCIL 1/2"x50/CAT50	0.500	0.768	1.575		3.465	2.715	1.969			1.575	55-105	2.9	14 000
●	1		684300-T	HG PENCIL 1/2"x100/CAT50	0.500	0.768	1.575		5.433	4.683	3.937			1.575	55-105	3	14 000
●	2		684310-T	HG PENCIL 1/2"x150/CAT50	0.500	0.768	1.575	0.965	7.402	6.652	5.906	2.953	1.969	1.575	55-105	3.2	10 000
●	3		684340-T	HG PENCIL 3/4"x110/CAT50	0.750	1.260	1.575		5.827	5.077	4.331	2.362		2.047	192-314	3.4	14 000
●	3		684350-T	HG PENCIL 3/4"x190/CAT50	0.750	1.260	1.575		8.976	8.226	7.480	2.362		2.047	192-314	4.1	10 000

* T = Min. and Max. transmittable torque using a h6 cylindrical tool, full depth insert. For additional information see section Technical Information.

For ISO equivalents, please contact ETP customer service; sales@etpinc.com

- From stock
- On request

Information:

- Runout accuracy ≤ 0.004 mm at $2.5 \times D1$ (max. 50 mm), ≤ 0.00016 inch at $2.5 \times D1$ (max. 1.969 inch)
- ≤ 0.007 mm at $2.5 \times D1$ at length $L1 > 125$ mm
- ≤ 0.00028 inch at $2.5 \times D1$ at length $L1 > 4.921$ inch
- Tool shank h6 or h7 can be used
- Coolant through on all holders
- Bore for data carrier

Accessories:

Use preset Torque Wrench, 6 Nm, to ensure correct mounting of tools. Part no. 19050.

ETP HYDRO-GRIPPENCIL can be used with reducing sleeves.

For additional information see section Accessories.



ETP HYDRO-GRIP® PENCIL

CAT Form AD/B - ASME B5.50 Dual Contact

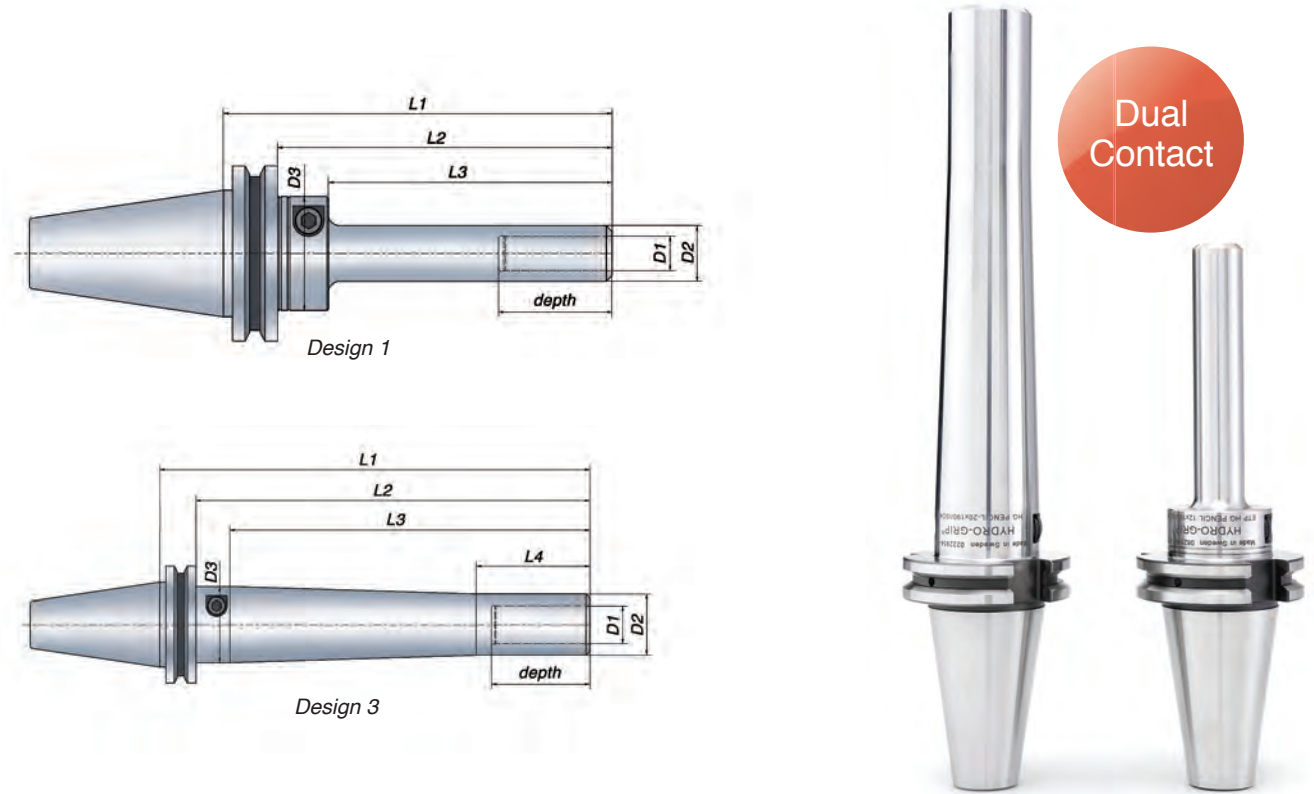

Metric range

Technical Specification CAT form AD/B Dual Contact

Design	Taper	Part no.	Item description	Dimensions, mm											depth	T* Nm	Weight kg	G 2.5 at rpm	
				D1	D2	D3	D4	L1	L2	L3	L4	L5							
● 1	40	684830	HG PENCIL-12x50/DC-CAT40	12	19.5	40		100	80.95	50						40	60-125	1.2	25 000
● 1		684840	HG PENCIL-12x100/DC-CAT40	12	19.5	40		150	130.95	100						40	60-125	1.3	15 000
● 3		684860	HG PENCIL-20x110/DC-CAT40	20	32	40		160	140.95	110	60					52	260-425	1.8	20 000

Inch range

Technical Specification CAT form AD/B Dual Contact

Design	Taper	Part no.	Item description	Dimensions, inch											depth	T* ft-lb	Weight kg	G 2.5 at rpm	
				D1	D2	D3	D4	L1	L2	L3	L4	L5							
● 1	40	684830-T	HG PENCIL-1/2"x50/DC-CAT40	0.500	0.768	1.575		3.937	3.187	1.969						1.575	55-105	1.2	25 000
● 1		684840-T	HG PENCIL-1/2"x100/DC-CAT40	0.500	0.768	1.575		5.906	5.156	3.937						1.575	55-105	1.3	15 000
● 3		684860-T	HG PENCIL-3/4"x110/DC-CAT40	0.750	1.220	1.575		6.299	5.549	4.331	2.362					2.047	192-314	1.8	20 000

*) T = Min. and Max. transmittable torque using a h6 cylindrical tool, full depth insert. For additional information see section Technical Information.

- From stock
- On request

Information:

- Runout accuracy ≤ 0.004 mm at $2.5 \times D1$ (max. 50 mm), ≤ 0.00016 inch at $2.5 \times D1$ (max. 1.969 inch)
- ≤ 0.007 mm at $2.5 \times D1$ at length $L1 > 125$ mm
- ≤ 0.00028 inch at $2.5 \times D1$ at length $L1 > 4.921$ inch
- Tool shank h6 or h7 can be used
- Coolant through on all holders
- Bore for data carrier

Accessories:

Use preset Torque Wrench, 6 Nm, to ensure correct mounting of tools. Part no. 19050.

ETP HYDRO-GRIP can be used with reducing sleeves. For additional information see section Accessories.



ETP HYDRO-GRIP®

PSK Form - ISO 26623-1

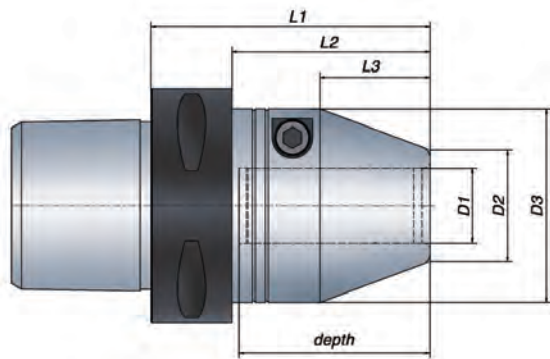

Metric range

Technical Specification PSK form

Coupling size	Part no.	Item description	Dimensions, mm									T* Nm	Weight kg	G 2.5 at rpm
			D1	D2	D3	L1	L2	L3	depth					
● **) C3	701558	HG-12/C3 (no gripper)	12	22	43.5	50	43	18	40	60-125	0.4	25 000		
● **) C4	703430	HG-12/C4 (no gripper)	12	22	43.5	50	43	18	40	60-125	0.5	25 000		
● C4	685160	HG-12/C4	12	22	43.5	62	43	18	40	60-125	0.6	25 000		
●	685170	HG-12x100/C4	12	22	43.5	100	43	18	40	60-125	1	25 000		
○	685180	HG-16/C4	16	26	48	72	52	28	50	165-270	0.7	25 000		
○	685190	HG-16x125/C4	16	26	48	125	52	28	50	165-270	1.2	25 000		
●	685200	HG-20/C4	20	30	52	75	55	30	52	260-425	0.8	25 000		
●	685210	HG-20x125/C4	20	30	52	125	105	30	52	260-425	1.6	25 000		
● C5	685220	HG-12/C5	12	22	43.5	62	42	18	40	60-125	0.8	25 000		
●	685230	HG-12x100/C5	12	22	43.5	100	80	18	40	60-125	1.2	25 000		
○	685240	HG-16/C5	16	26	48	72	52	28	50	165-270	1	25 000		
○	685250	HG-16x125/C5	16	26	48	125	105	28	50	165-270	1.5	25 000		
●	685260	HG-20/C5	20	30	52	74	54	30	52	260-425	1	25 000		
●	685270	HG-20x125/C5	20	30	52	125	54	30	52	260-425	1.8	25 000		
●	685280	HG-25/C5	25	35	59	79	59	34	56	480-710	1.2	25 000		

Inch range

Technical Specification PSK form

Coupling size	Part no.	Item description	Dimensions, inch									T* ft-lb	Weight kg	G 2.5 at rpm
			D1	D2	D3	L1	L2	L3	depth					
● C4	685200-T	HG-3/4"/C4	0.750	1.181	2.047	2.953	2.165	1.181	2.047	192-314	0.8	25 000		
● C5	685280-T	HG-1"/C5	1.000	1.378	2.323	3.110	2.323	1.339	2.205	354-524	1.2	25 000		

*) T = Min. and Max transmittable torque using a h6 cylindrical tool, full depth insert. For additional information see section Technical Information.

Additional PSK Inch equivalents add "-T" to metric part no. Available on request.

**) Short version with no gripper grooves.

- From stock
- On request

Information:

- Runout accuracy ≤ 0.004 mm at $2.5 \times D1$ (max. 50 mm), ≤ 0.00016 inch at $2.5 \times D1$ (max. 1.969 inch)
- Tool shank h6 or h7 can be used
- Center thread, M8x1.25, for axial length adjustment screw (screw not included)
- Coolant through on all holders
- Bore for data carrier

Accessories:

Use preset Torque Wrench, 6 Nm, to ensure correct mounting of tools. Part no. 19050.

ETP HYDRO-GRIP can be used with reducing sleeves. For additional information see section Accessories.



ETP HYDRO-GRIP®

PSK Form - ISO 26623-1

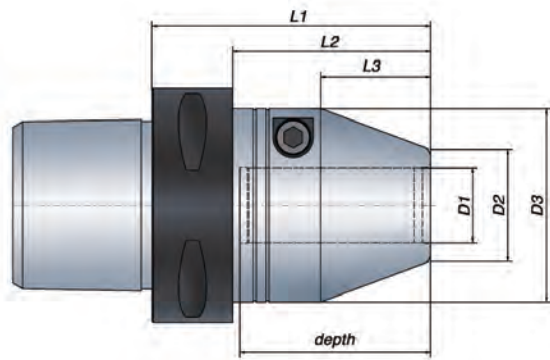

Metric range

Technical Specification PSK form

Coupling size	Part no.	Item description	Dimensions, mm									T* Nm	Weight kg	G 2.5 at rpm
			D1	D2	D3	L1	L2	L3	depth					
●	685290	HG-12/C6	12	22	43.5	64	42	18	40	60-125	1.1	25 000		
	685300	HG-12x100/C6	12	22	43.5	100	78	18	40	60-125	1.5	25 000		
	○	685310	HG-16/C6	16	26	48	74	52	28	50	165-270	1.2	25 000	
	○	685320	HG-16x125/C6	16	26	48	125	103	28	50	165-270	1.7	25 000	
	●	685330	HG-20/C6	20	30	52	76	54	30	52	260-425	1.3	25 000	
	●	685340	HG-20x150/C6	20	30	52	150	128	30	52	260-425	2.5	25 000	
	●	685350	HG-25/C6	25	35	59	80	58	34	56	480-710	1.5	25 000	
	●	685360	HG-25x150/C6	25	35	59	150	128	34	56	480-710	3	25 000	
	●	685370	HG-32/C6	32	42	69.5	84	62	38	60	820-1250	1.8	25 000	
○	685380	HG-12/C8	12	22	43.5	67	37	18	40	60-125	2.1	14 000		
	685390	HG-12x100/C8	12	22	43.5	100	70	18	40	60-125	2.5	14 000		
	685400	HG-16/C8	16	26	48	77	47	28	50	165-270	2.2	14 000		
	685410	HG-16x125/C8	16	26	48	125	95	28	50	165-270	2.7	14 000		
	●	685420	HG-20/C8	20	30	52	79	49	30	52	260-425	2.3	14 000	
	●	685430	HG-20x150/C8	20	30	52	150	120	30	52	260-425	3.4	14 000	
	●	685440	HG-25/C8	25	35	59	83	53	34	56	480-710	2.4	14 000	
	●	685450	HG-25x150/C8	25	35	59	150	120	34	56	480-710	3.8	14 000	
	●	685460	HG-32/C8	32	42	69.5	87	57	38	60	820-1250	2.7	14 000	

Inch range

Technical Specification PSK form

Coupling size	Part no.	Item description	Dimensions, inch									T* Nm	Weight kg	G 2.5 at rpm
			D1	D2	D3	L1	L2	L3	depth					
C6	685290-T	HG-1/2"/C6	0.500	0.866	1.713	2.520	1.654	0.709	1.575	55-105	1.1	25 000		
	685330-T	HG-3/4"/C6	0.750	1.181	2.047	2.992	2.126	1.181	2.047	192-314	1.3	25 000		
	685350-T	HG-1"/C6	1.000	1.378	2.323	3.150	2.283	1.339	2.205	354-524	1.5	25 000		

*) T = Min. and Max transmittable torque using a h6 cylindrical tool, full depth insert. For additional information see section Technical Information.

Additional PSK Inch equivalents add "-T" to metric part no. Available on request.

- From stock
- On request

Information:

- Runout accuracy ≤ 0.004 mm at $2.5 \times D1$ (max. 50 mm), ≤ 0.00016 inch at $2.5 \times D1$ (max. 1.969 inch)
- Tool shank h6 or h7 can be used
- Center thread, M8x1.25, for axial length adjustment screw (screw not included)
- Coolant through on all holders
- Bore for data carrier

Accessories:

Use preset Torque Wrench, 6 Nm, to ensure correct mounting of tools. Part no. 19050.

ETP HYDRO-GRIP can be used with reducing sleeves. For additional information see section Accessories.



ETP HYDRO-GRIP® HD

PSK Form - ISO 26623-1

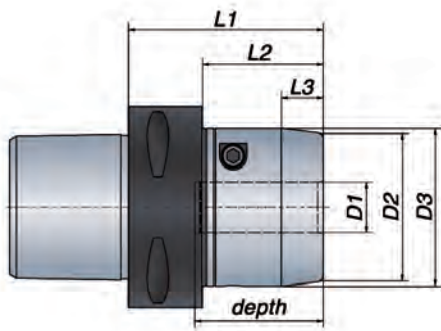

Metric range

Technical Specification PSK form

Coupling size	Part no.	Item description	Dimensions, mm										T* Nm	Weight kg	G 2.5 at rpm
			D1	D2	D3	L1	L2	L3	depth						
● C5	682040	HG HD-20/C5	20	59	63	79	59	17	52	400-535	1.6	25 000			
● C6	682050	HG HD-20/C6	20	59	63	73		17	52	400-535	1.8	25 000			
●	682060	HG HD-25/C6	25	70	74	80	58	17	56	740-940	2.4	25 000			
●	682070	HG HD-32/C6	32	76	80	86	64	17	60	1325-1670	2.8	25 000			
● C8	682080	HG HD-20/C8	20	59	63	79	49	17	52	400-535	2.8	14 000			
●	682090	HG HD-25/C8	25	70	74	83	53	17	56	740-940	3.3	14 000			
●	682100	HG HD-32/C8	32	76	80	87		17	60	1325-1670	3.5	14 000			

Inch range

Technical Specification PSK form

Coupling size	Part no.	Item description	Dimensions, inch										T* ft-lb	Weight kg	G 2.5 at rpm
			D1	D2	D3	L1	L2	L3	depth						
○ C5	682040-T	HG HD-3/4"/C5	0.750	2.323	2.480	3.110	2.323	0.669	2.047	295 - 395	1.6	25 000			
● C6	682050-T	HG HD-3/4"/C6	0.750	2.323	2.480	2.874		0.669	2.047	295 - 395	1.8	25 000			
○	682060-T	HG HD-1"/C6	1.000	2.756	2.913	3.150	2.283	0.669	2.205	546 - 693	2.4	25 000			
●	682070-T	HG HD-1 1/4"/C6	1.250	2.992	3.150	3.386	2.520	0.669	2.362	977 - 1232	2.8	25 000			
○ C8	682080-T	HG HD-3/4"/C8	0.750	2.323	2.480	3.110	1.929	0.669	2.047	295 - 395	2.8	14 000			
○	682090-T	HG HD-1"/C8	1.000	2.756	2.913	3.268	2.087	0.669	2.205	546 - 693	3.3	14 000			
●	682100-T	HG HD-1 1/4"/C8	1.250	2.992	3.150	3.425		0.669	2.362	977 - 1232	3.5	14 000			

*) T = Min. and Max transmittable torque using a h6 cylindrical tool, full depth insert. For additional information see section Technical Information.

- From stock
- On request

Information:

- Runout accuracy ≤ 0.004 mm at 2.5 x D1 (max. 50 mm), ≤ 0.00016 inch at 2.5x D1 (max. 1.969 inch)
- Tool shank h6 or h7 can be used
- Center thread, M12x1, for axial length adjustment screw (screw not included)
- Coolant through on all holders
- Bore for data carrier - available on request

Accessories:

Use preset Torque Wrench, 10 Nm, to ensure correct mounting of tools. Part no. 19052.

ETP HYDRO-GRIP can be used with reducing sleeves. For additional information see section Accessories.



ETP HYDRO-GRIP® PENCIL PSK Form - ISO 26623-1

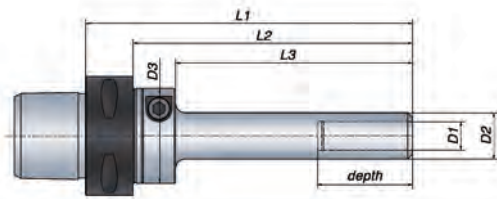

Design 1

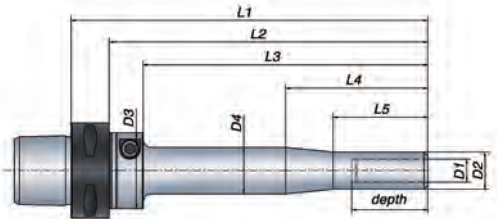

Design 2

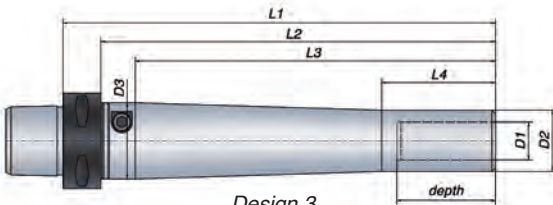

Design 3



Metric range

Technical Specification PSK form				Dimensions, mm											T* Nm	Weight kg	G 2.5 at rpm
Design	Coupling size	Part no.	Item description	D1	D2	D3	D4	L1	L2	L3	L4	L5	depth				
●	1	C4	683210	HG PENCIL-6x50/C4	6	12	40		88		50			40	12-22	0.5	25 000
○	1		683180	HG PENCIL-8x50/C4	8	14.5	40		88		50			40	27-40	0.5	25 000
○	1		683200	HG PENCIL-10x50/C4	10	17	40		88		50			40	35-70	0.5	25 000
○	1		683190	HG PENCIL-10x100/C4	10	17	40		138		100			40	35-70	0.6	15 000
●	1		683220	HG PENCIL-12x50/C4	12	19.5	40		88		50			40	60-125	0.5	25 000
●	1		683230	HG PENCIL-12x100/C4	12	19.5	40		138		100			40	60-125	0.6	15 000
●	2		683240	HG PENCIL-12x150/C4	12	19.5	40	24.5	188		150	75	50	40	60-125	0.8	10 000
●	1	C5	683310	HG PENCIL-6x50/C5	6	12	40		88	68	50			40	12-22	0.6	25 000
○	1		683250	HG PENCIL-8x50/C5	8	14.5	40		88	68	50			40	27-40	0.6	25 000
○	1		683270	HG PENCIL-10x50/C5	10	17	40		88	68	50			40	35-70	0.6	25 000
○	1		683260	HG PENCIL-10x100/C5	10	19.5	40		138	118	100			40	35-70	0.7	15 000
●	1		683320	HG PENCIL-12x50/C5	12	19.5	40		88	68	50			40	60-125	0.6	25 000
●	1		683330	HG PENCIL-12x100/C5	12	19.5	40		138	118	100			40	60-125	0.7	15 000
●	2		683300	HG PENCIL-12x150/C5	12	19.5	40	24.5	188	168	150	75	50	40	60-125	0.9	10 000
○	1		683290	HG PENCIL-16x75/C5	16	26	40		113	93	75			50	165 - 270	0.8	15 000
○	1		683280	HG PENCIL-16x125/C5	16	26	40		163	143	125			50	165 - 270	1	10 000
●	3		683340	HG PENCIL-20x110/C5	20	32	40		148	128	110	60		52	260 - 425	1.2	20 000
●	3		683350	HG PENCIL-20x190/C5	20	32	40		228	208	190	60		52	260 - 425	1.9	10 000

*) T = Min. and Max transmittable torque using a h6 cylindrical tool, full depth insert. For additional information see section Technical Information.

PSK Inch equivalents add "-T" to metric part no. Available on request.

- From stock
- On request

Information:

- Runout accuracy ≤ 0.004 mm at $2.5 \times D1$ (max. 50 mm), ≤ 0.00016 inch at $2.5 \times D1$ (max. 1.969 inch)
- ≤ 0.007 mm at $2.5 \times D1$ at length $L1 > 125$ mm
- ≤ 0.00028 inch at $2.5 \times D1$ at length $L1 > 4.921$ inch
- Tool shank h6 or h7 can be used
- Coolant through on all holders
- Bore for data carrier - available on request

Accessories:

Use preset Torque Wrench, 6 Nm, to ensure correct mounting of tools. Part no. 19050.

ETP HYDRO-GRIP PENCIL can be used with reducing sleeves. For additional information see section Accessories.



ETP HYDRO-GRIP® PENCIL PSK Form - ISO 26623-1

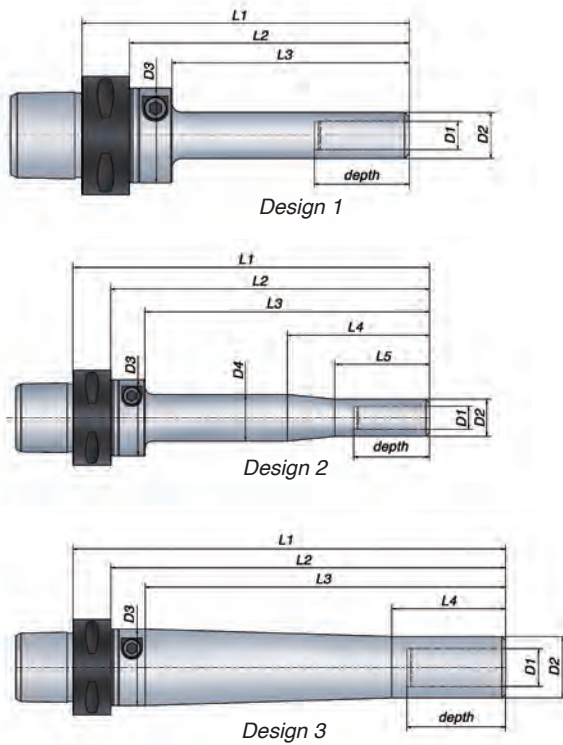

Metric range

Technical Specification PSK form				Dimensions, mm													
Design	Coupling size	Part no.	Item description	D1	D2	D3	D4	L1	L2	L3	L4	L5	depth	T* Nm	Weight kg	G 2.5 at rpm	
●	1	C6	683430	HG PENCIL-6x50/C6	6	12	40		90	68	50			40	12-22	1	25 000
○	1		683360	HG PENCIL-8x50/C6	8	14.5	40		90	68	50			40	27-40	1	25 000
○	1		683380	HG PENCIL-10x50/C6	10	17	40		90	68	50			40	35-70	1	25 000
○	1		683370	HG PENCIL-10x100/C6	10	17	40		140	118	100			40	35-70	1.1	15 000
●	1		683440	HG PENCIL-12x50/C6	12	19.5	40		90	68	50			40	60-125	1	25 000
●	1		683450	HG PENCIL-12x100/C6	12	19.5	40		140	118	100			40	60-125	1.1	15 000
●	2		683410	HG PENCIL-12x150/C6	12	19.5	40	24.5	190	168	150	75	50	40	60-125	1.3	10 000
○	1		683400	HG PENCIL-16x75/C6	16	26	40		115	93	75			50	165 - 270	1.2	15 000
○	1		683390	HG PENCIL-16x125/C6	16	26	40		165	143	125			50	165 - 270	1.4	10 000
●	3		683460	HG PENCIL-20x110/C6	20	32	40		150	128	110	60		52	260 - 425	1.6	20 000
●	3		683420	HG PENCIL-20x190/C6	20	32	40		230	208	190	60		52	260 - 425	2.2	10 000
○	1	C8	683480	HG PENCIL-10x50/C8	10	17	40		102	72	50			40	35-70	2.1	14 000
○	1		683470	HG PENCIL-10x100/C8	10	17	40		152	122	100			40	35-70	2.2	14 000
●	1		683510	HG PENCIL-12x50/C8	12	19.5	40		102	72	50			40	60-125	2.1	14 000
●	1		683520	HG PENCIL-12x100/C8	12	19.5	40		152	122	100			40	60-125	2.2	14 000
●	2		683540	HG PENCIL-12x150/C8	12	19.5	40	24.5	202	172	150	75	50	40	60-125	2.4	10 000
○	1		683500	HG PENCIL-16x75/C8	16	26	40		127	97	75			50	165 - 270	2.3	14 000
○	1		683490	HG PENCIL-16x125/C8	16	26	40		177	147	125			50	165 - 270	2.5	10 000
●	3		683530	HG PENCIL-20x110/C8	20	32	40		162	132	110	60		52	260 - 425	2.6	14 000
●	3		683550	HG PENCIL-20x190/C8	20	32	40		242	212	190	60		52	260 - 425	3.3	10 000

*) T = Min. and Max transmittable torque using a h6 cylindrical tool, full depth insert. For additional information see section Technical Information.

PSK Inch equivalents add "-T" to metric part no. Available on request.

- From stock
- On request

Information:

- Runout accuracy ≤ 0.004 mm at $2.5 \times D1$ (max. 50 mm), ≤ 0.00016 inch at $2.5 \times D1$ (max. 1.969 inch)
- ≤ 0.007 mm at $2.5 \times D1$ at length $L1 > 125$ mm
- ≤ 0.00028 inch at $2.5 \times D1$ at length $L1 > 4.921$ inch
- Tool shank h6 or h7 can be used
- Coolant through on all holders
- Bore for data carrier - available on request

Accessories:

Use preset Torque Wrench, 6 Nm, to ensure correct mounting of tools. Part no. 19050.

ETP HYDRO-GRIP PENCIL can be used with reducing sleeves.
For additional information see section Accessories.



ETP HYDRO-GRIP® PENCIL

Cylindrical extension

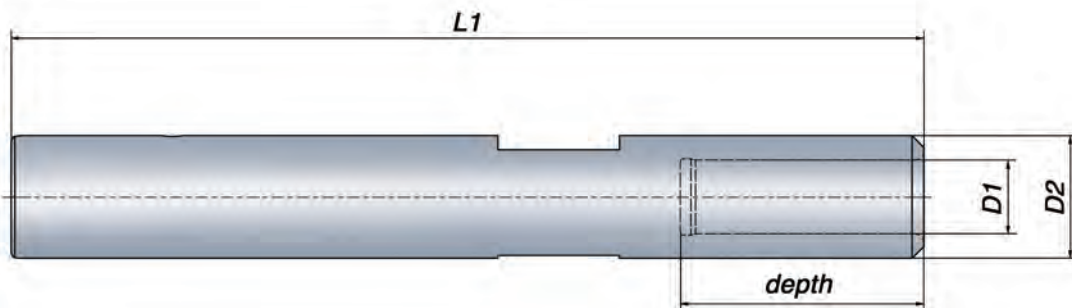
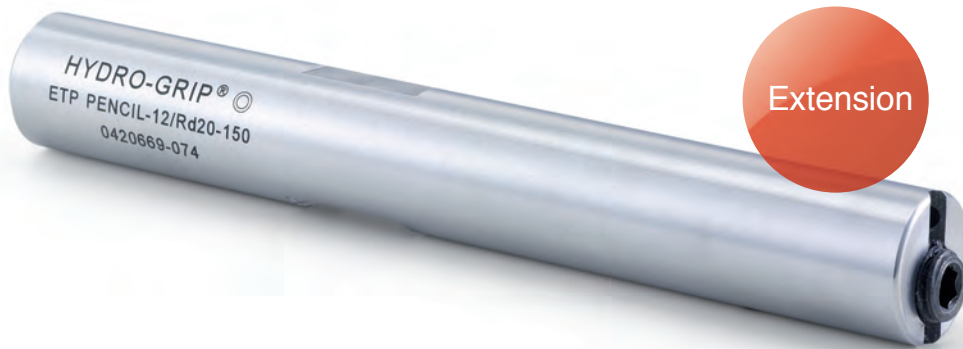

Metric range

Technical Specification

Part no.	Item description	D1	D2	L1	Dimensions, mm			
					depth	T* Nm	Weight kg	G 2.5 at rpm
336891	HG PENCIL-12/Rd20-150	12	20	150	40	60 - 125	0.3	15 000

*) T = Min. and Max transmittable torque using a h6 cylindrical tool, full depth insert. For additional information see section Technical Information.

- From stock
- On request

Information:

- Runout accuracy ≤ 0.004 mm at $2.5 \times D1$ (max. 50 mm), ≤ 0.00016 inch at $2.5 \times D1$ (max. 1.969 inch)
- Tool shank h6 or h7 can be used
- Coolant through

Accessories:

Use preset Torque Wrench, 6 Nm, to ensure correct mounting of tools. Part no. 19050.

ETP HYDRO-GRIP PENCIL can be used with reducing sleeves. For additional information see section Accessories.



ETP ECOGRIP™ ER

For outer threaded toolholders and driven tools

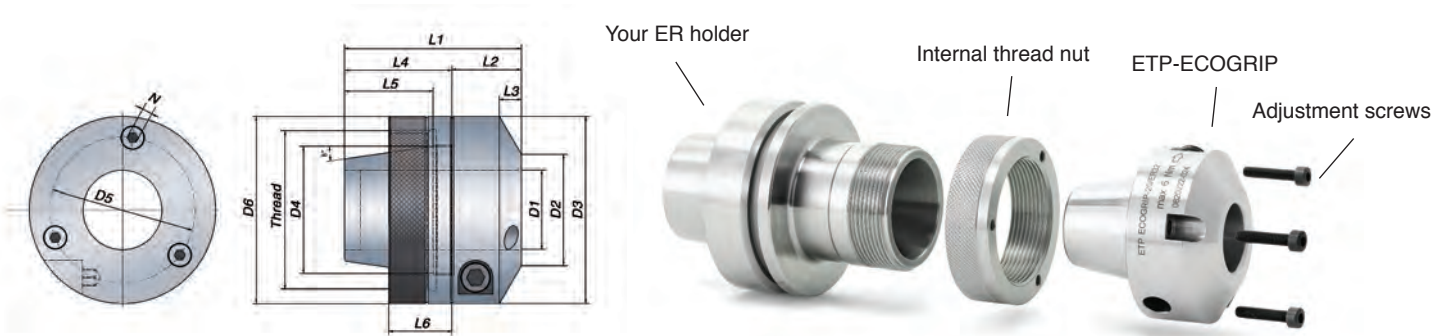

Metric range

Technical Specification																			
ER size	Part no.	Item description	Dimensions, mm									Adjustment screws				Internal thread nut			T* Nm
			D1	D2	D3	D4	L1	L2	L3	L4	L5	D5	No.	Dim.	N	D6	L6	Thread	
● 16	686845	ETP ECOGRIP-6/ER16	6	16	34	16	30	14	5	16	14	28	2	M3x16*	2.5	34	10	M22x1.5	6-14
●	686846	ETP ECOGRIP-6/ERM16	6	16	34	16	30	14	5	16	14	28	2	M3x16*	2.5	34	10	M19x1	6-14
● 20	686855	ETP ECOGRIP-12/ER20	12	22	43.5	20	40	24	7	16	14	34	3	M4x20	3	43.5	12	M25x1.5	50-90
●	686856	ETP ECOGRIP-12/ERM20	12	22	43.5	20	40	24	7	16	14	34	3	M4x20	3	43.5	12	M24x1	50-90
● 25	686905	ETP ECOGRIP-12/ER25	12	26	48	25	46	26	7	20	18	41	3	M4x20	3	48	13	M32x1.5	50-90
●	686906	ETP ECOGRIP-12/ERM25	12	26	48	25	46	26	7	20	18	41	3	M4x20	3	48	13	M30x1	50-90
●	686875	ETP ECOGRIP-16/ER25	16	26	48	25	46	26	7	20	18	41	3	M4x20	3	48	13	M32x1.5	120-200
●	686876	ETP ECOGRIP-16/ERM25	16	26	48	25	46	26	7	20	18	41	3	M4x20	3	48	13	M30x1	120-200
● 32	686865	ETP ECOGRIP-20/ER32	20	30	52	32	52	25.5	7	26.5	24.5	45	3	M4x20	3	52	15	M40x1.5	230-370
● 40	686885	ETP ECOGRIP-25/ER40	25	35	59	40	56	22	7	34	28	46	3	M4x16	3	59	20	M50x1.5	420-600
● 50	686895	ETP ECOGRIP-32/ER50**	32	42	69.5	50	60	22	7	38	32	56	3	M4x15	3	78	20	M64x2	660-1000

Inch range

Technical Specification																			
ER size	Part no.	Item description	Dimensions, inch									Adjustment screws				Internal thread nut			T* ft-lb
			D1	D2	D3	D4	L1	L2	L3	L4	L5	D5	No.	Dim.	N	D6	L6	Thread	
● 16	686945	ETP ECOGRIP-1/4"/ER16	0.250	0.630	1.339	0.630	1.181	0.551	0.197	0.630	0.551	1.102	2	M3x16*	0.098	1.339	0.394	M22x1.5	4.4-10
● 20	686955	ETP ECOGRIP-1/2"/ER20	0.500	0.866	1.713	0.787	1.575	0.945	0.276	0.630	0.551	1.339	3	M4x20	0.118	1.713	0.472	M25x1.5	37-66
●	686956	ETP ECOGRIP-1/2"/ERM20	0.500	0.866	1.713	0.787	1.575	0.945	0.276	0.630	0.551	1.339	3	M4x20	0.118	1.713	0.472	M24x1	37-66
● 25	687005	ETP ECOGRIP-1/2"/ER25	0.500	1.024	1.890	0.984	1.811	1.024	0.276	0.787	0.709	1.614	3	M4x20	0.118	1.890	0.512	M32x1.5	37-66
●	686975	ETP ECOGRIP-5/8"/ER25	0.625	1.024	1.890	0.984	1.811	1.024	0.276	0.787	0.709	1.614	3	M4x20	0.118	1.890	0.512	M32x1.5	89-148
● 32	686965	ETP ECOGRIP-3/4"/ER32	0.750	1.181	2.047	1.260	2.047	1.004	0.276	1.043	0.965	1.772	3	M4x20	0.118	2.047	0.591	M40x1.5	170-273
● 40	686985	ETP ECOGRIP-1"/ER40	1.000	1.378	2.323	1.575	2.205	0.866	0.276	1.339	1.102	1.811	3	M4x16	0.118	2.323	0.787	M50x1.5	310-443
○ 50	686995	ETP ECOGRIP-1 1/4"/ER50**	1.250	1.654	2.736	1.969	2.362	0.866	0.276	1.496	1.260	2.205	3	M4x15	0.118	3.071	0.787	M64x2	487-738

* This size ECOGRIP ER has 2x M3x16 adjustment screws located 180 degrees apart. It also has an additional 2x M5x8 adjustment screws, located 180 degrees apart, at the back of the thread nut.

** The thread nut width L6 of this size ECOGRIP ER is 20 mm. The thread depth is however only 15 mm.

*) T = Min. and Max transmittable torque using a h6 cylindrical tool, full depth insert. For additional information see section Technical Information.

- From stock
- On request

Information:

- Runout accuracy - adjustable!
- When mounted correctly, an initial runout of approx. 0.020 mm is achieved. Adjust runout further by lightly tightening on the adjustment screws until your desired runout is achieved.
- Tool shank h6 or h7 can be used
- Balanced by design. For use above 5 - 10 000 rpm – we recommend individual balancing.

Accessories:

Use preset Torque Wrench, 6 Nm, to ensure correct mounting of tools. Part no. 19050.

ETP ECOGRIP ER can be used with reducing sleeves. For additional information see section Accessories.



ETP ECOGRIP™ ER

For inner threaded driven tools

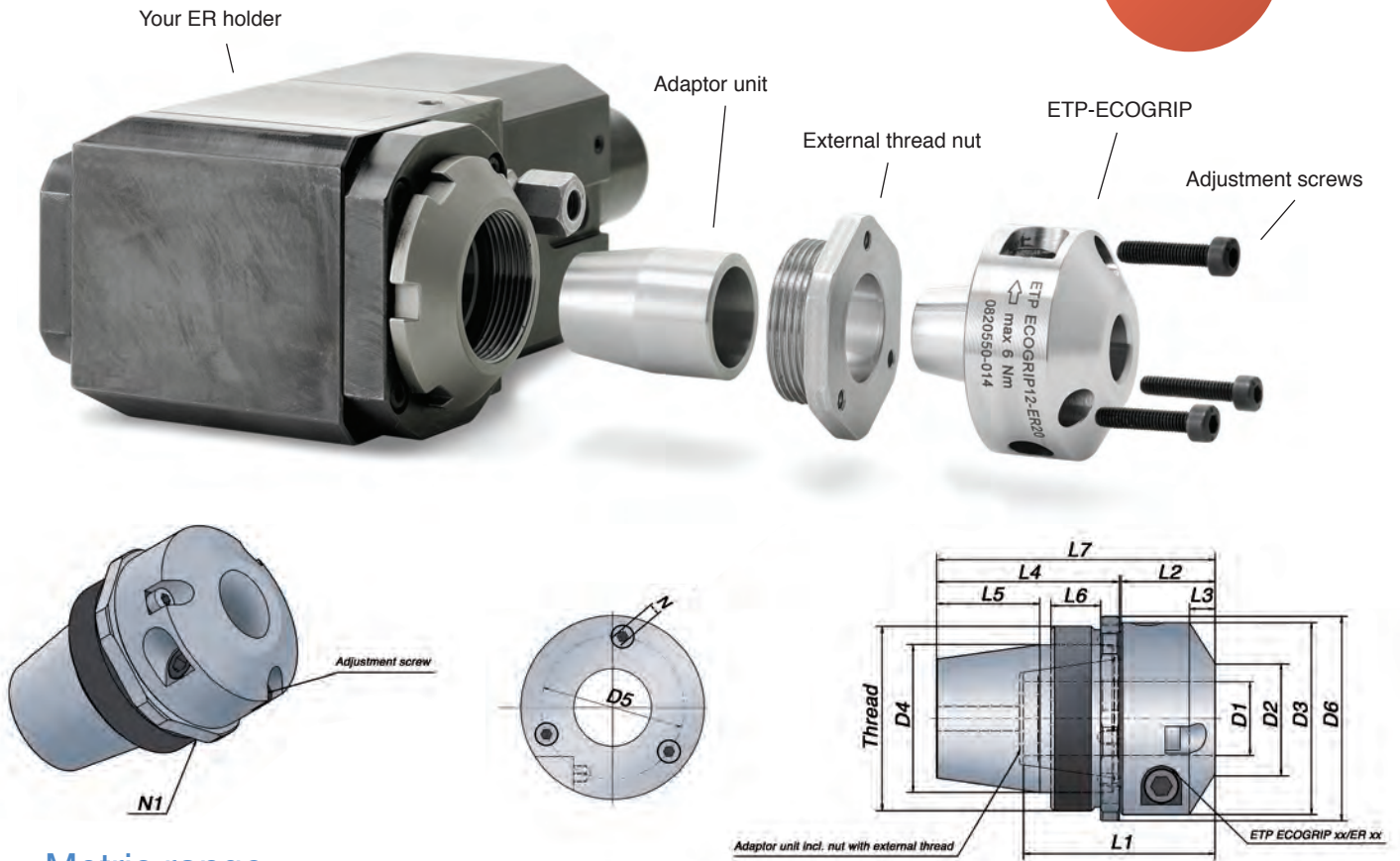

Metric range

Technical Specification

ER size	Part no.	Item description	Dimensions, mm										Adjustment screws				External thread nut				T* Nm	
			D1	D2	D3	D4	L1	L2	L3	L4	L5	L7	D5	No.	Dim.	N	D6	L6	Thread	N1		Tt Nm
25	687310	ETP ECOGRIP-12/ER20-25	12	22	43.5	25	40	24	7	36	18	60.5	34	3	M4x16	3	43.5	10	M32x1.5	40	50	50-90
32	687320	ETP ECOGRIP-12/ER25-32	12	26	48	32	46	26	7	44.5	24.5	71	41	3	M4x16	3	48	12	M40x1.5	44	104	50-90
32	687330	ETP ECOGRIP-16/ER25-32	16	26	48	32	46	26	7	44.5	24.5	71	41	3	M4x16	3	48	12	M40x1.5	44	104	120-200
40	687340	ETP ECOGRIP-20/ER32-40	20	30	52	40	52	25.5	7	49.5	28	75.5	45	3	M4x16	3	56	13.5	M50x1.5	52	128	230-370

Inch range

Technical Specification

ER size	Part no.	Item description	Dimensions, inch										Adjustment screws				External thread nut				T* ft-lb	
			D1	D2	D3	D4	L1	L2	L3	L4	L5	L7	D5	No.	Dim.	N	D6	L6	Thread	N1		Tt Nm
25	687410	ETP ECOGRIP-1/2"/ER20-25	0.500	0.866	1.713	0.984	1.575	0.945	0.276	1.417	0.709	2.382	1.339	3	M4x16	0.118	1.713	0.394	M32x1.5	1.575	50	37-66
32	687420	ETP ECOGRIP-1/2"/ER25-32	0.500	1.024	1.890	1.260	1.811	1.024	0.276	1.752	0.965	2.795	1.614	3	M4x16	0.118	1.890	0.472	M40x1.5	1.732	104	37-66
32	687430	ETP ECOGRIP-5/8"/ER25-32	0.625	1.024	1.890	1.260	1.811	1.024	0.276	1.752	0.965	2.795	1.614	3	M4x16	0.118	1.890	0.472	M40x1.5	1.732	104	89-148
40	687440	ETP ECOGRIP-3/4"/ER32-40	0.750	1.181	2.047	1.575	2.047	1.004	0.276	1.949	1.102	2.972	1.772	3	M4x16	0.118	2.205	0.531	M50x1.5	2.047	128	170-273

Tt: Recommended tightening torque in Nm for the External thread nut.

*) T = Min. and Max transmittable torque using a h6 cylindrical tool, full depth insert. For additional information see section Technical Information.

- From stock
- On request

Information:

- Runout accuracy - adjustable!
When mounted correctly, an initial runout of approx. 0.020 mm is achieved.
Adjust runout further by lightly tightening on the adjustment screws until your desired runout is achieved.
- Tool shank h6 or h7 can be used
- Balanced by design

Accessories:

Use preset Torque Wrench, 6 Nm, to ensure correct mounting of tools. Part no. 19050.

ETP ECOGRIP ER can be used with reducing sleeves.
For additional information see section Accessories.



Reduction Sleeves for ETP Toolholders



Reduction sleeve HS - for internal cooling

The reduction sleeves are designed to fit with the ETP Toolholders. They are specially suited for high precision clamping of cylindrical tool shanks per DIN 6335 form HA, HB and HE, as well as tool shanks per DIN 1835 form B, C, D and E.

The special design of the reduction sleeves allows an efficient use of coolant through cutting tools.

Reduction sleeve HS-CF - for peripheral cooling.

Outer-Ø of reduction sleeve corresponds to the type.

HS12 = Ø 12 mm
 HS20 = Ø 20 mm
 HS25 = Ø 25 mm
 HS32 = Ø 32 mm

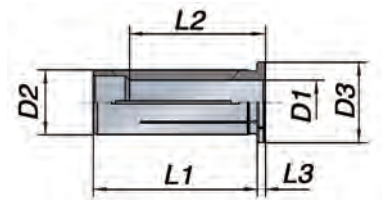

BENEFITS & FEATURES

- Standard version HS suited for internal cooling**
 Metal-to-metal seal for cutting tools with internal coolant channels.
- HS-CF version suited for peripheral cooling**
 The coolant flush reduction sleeves HS-CF can be used for peripheral cooling due to their coolant channels.
- Accurate precision**
 High runout accuracy < 3 µm.
- High flexibility**
 Clamping of different tool shank diameters. 12, 20, 25, 32 mm and 1/2", 3/4", 1", 1 1/4".
- Power increase**
 When using reduction sleeves the transmittable torque is increased.

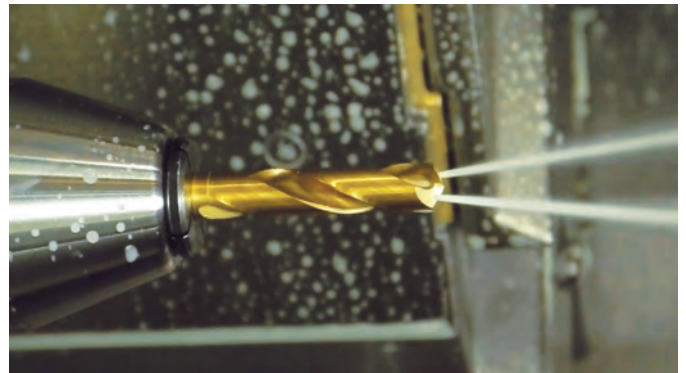

Using Reduction sleeve HS - for internal cooling.

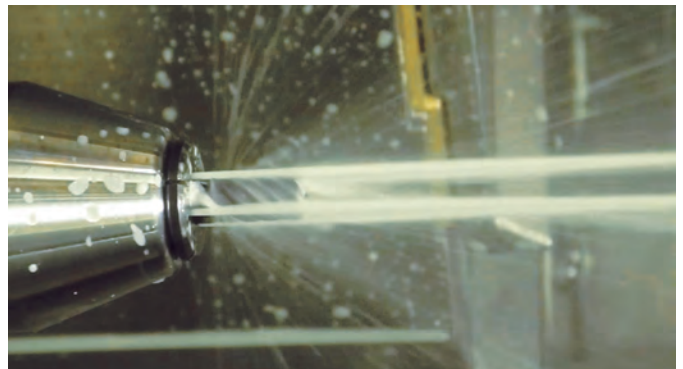

Using Reduction sleeve HS-CF - for peripheral cooling.

Reduction Sleeves

mm to inch

Reduction Sleeves mm to inch							
Item description	D1 inch	Part no.	D2 mm	D3 mm	L1 mm	L2 mm	L3 mm
Reduction Sleeves HS 12							
● HS 12 / 1/8"	0.1250	R1912.03181	12	16	40	29	4
● HS 12 / 3/16"	0.1875	R1912.04761	12	16	40	29	4
● HS 12 / 1/4"	0.2500	R1912.06351	12	16	40	29	4
● HS 12 / 5/16"	0.3125	R1912.07941	12	16	40	36	4
● HS 12 / 3/8"	0.3750	R1912.09521	12	16	40	37	4
Reduction Sleeves HS 20							
● HS 20 / 1/8"	0.1250	R1920.03181	20	25	50	28	4
● HS 20 / 3/16"	0.1875	R1920.04761	20	25	50	28	4
● HS 20 / 1/4"	0.2500	R1920.06351	20	25	50	36	4
● HS 20 / 5/16"	0.3125	R1920.07941	20	25	50	37	4
● HS 20 / 3/8"	0.3750	R1920.09521	20	25	50	36	4
● HS 20 / 7/16"	0.4375	R1920.11111	20	25	50	40	4
● HS 20 / 1/2"	0.5000	R1920.12701	20	25	50	45	4
● HS 20 / 9/16"	0.5625	R1920.14291	20	25	50	45	4
● HS 20 / 5/8"	0.6250	R1920.15881	20	25	50	48	4
Reduction Sleeves HS 25							
● HS 25 / 1/8"	0.1250	R1925.03181	25	30	56	29	4
○ HS 25 / 3/16"	0.1875	R1925.04761	25	30	56	29	4
● HS 25 / 1/4"	0.2500	R1925.06351	25	30	56	37	4
○ HS 25 / 5/16"	0.3125	R1925.07941	25	30	56	37	4
● HS 25 / 3/8"	0.3750	R1925.09521	25	30	56	38	4
○ HS 25 / 7/16"	0.4375	R1925.11111	25	30	56	40	4
● HS 25 / 1/2"	0.5000	R1925.12701	25	30	56	46	4
○ HS 25 / 9/16"	0.5625	R1925.14291	25	30	56	47	4
● HS 25 / 5/8"	0.6250	R1925.15881	25	30	56	48	4
○ HS 25 / 11/16"	0.6875	R1925.17461	25	30	56	48	4
● HS 25 / 3/4"	0.7500	R1925.19051	25	30	56	48	4
○ HS 25 / 13/16"	0.8125	R1925.20631	25	30	56	50	4
Reduction Sleeves HS 32							
○ HS 32 / 3/16"	0.1875	R1932.04761	32	36	60	29	4
○ HS 32 / 1/4"	0.2500	R1932.06351	32	36	60	36	4
○ HS 32 / 5/16"	0.3125	R1932.07941	32	36	60	36	4
● HS 32 / 3/8"	0.3750	R1932.09521	32	36	60	37	4
○ HS 32 / 7/16"	0.4375	R1932.11111	32	36	60	45	4
● HS 32 / 1/2"	0.5000	R1932.12701	32	36	60	45	4
○ HS 32 / 9/16"	0.5625	R1932.14291	32	36	60	46	4
● HS 32 / 5/8"	0.6250	R1932.15881	32	36	60	46	4
○ HS 32 / 11/16"	0.6875	R1932.17461	32	36	60	48	4
● HS 32 / 3/4"	0.7500	R1932.19051	32	36	60	50	4
○ HS 32 / 13/16"	0.8125	R1932.20631	32	36	60	50	4
● HS 32 / 7/8"	0.8750	R1932.22221	32	36	60	50	4
○ HS 32 / 15/16"	0.9375	R1932.23811	32	36	60	52	4
● HS 32 / 1"	1.000	R1932.25401	32	36	60	56	4

Accessories

Torque wrench and Extractor



Comparison of Transmittable Torque at Ø 20 mm

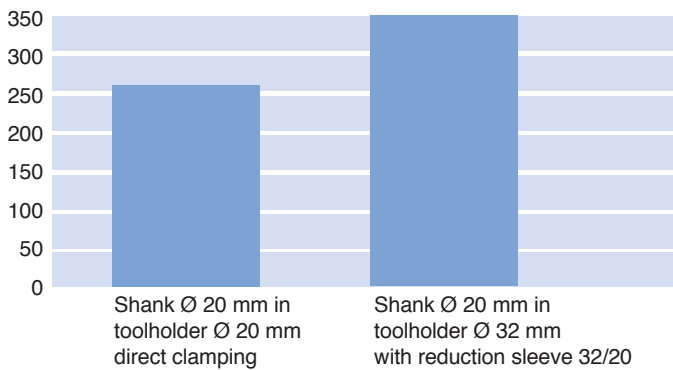

HYDRO-GRIP Torque wrench

Use torque wrench to ensure correct tightening independent on user. Should be used with all HYDRO-GRIP® holders.

Torque: 6 Nm:
HYDRO-GRIP, HYDRO-GRIP PENCIL, ECOGRIP.
Torque: 10 Nm:
HYDRO-GRIP HD.

Item description	Tightening torque:		Part no.
	Nm	ft · lb	
● HYDRO-GRIP Torque wrench (5 mm Hex)	6	4.4	19050
● HYDRO-GRIP HD Torque wrench (5 mm Hex)	10	7.4	19052

Extractor

Item description	Part no.	For Sizes	A	B
			[mm]	[mm]
● EHS 12 - 1/2"	E7321.12000	HS 12	24.6	100
● EHS 20 - 3/4"	E7321.20000	HS 20	38.0	160
● EHS 25 - 1"	E7321.25000	HS 25	51.0	180
● EHS 32 - 1 1/4"	E7321.32000	HS 32	63.0	200

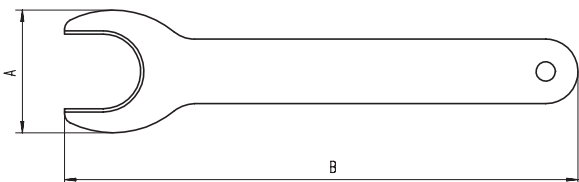

The extractor helps to remove the reduction sleeve from the toolholder.

- Improper assembly can damage the concentricity of the reduction sleeve.
- Insert tools the full length of the reduction sleeve.
- Tool shank h6 or h7 can be used.
- Do not clamp reduction sleeve without a tool. Reduction Sleeve will be damaged.

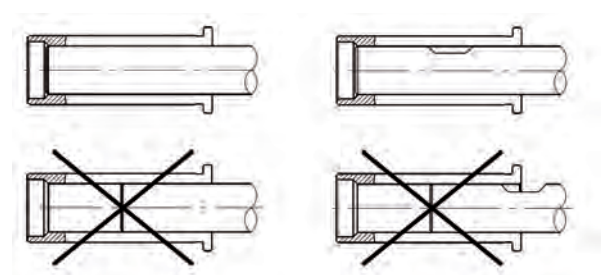

Transmittable torque

The tables gives the minimum transmittable torque depending on the tool diameter and tolerance.

For optimal performance and precision we recommend the use of h6-tools. Also tools with h7 tolerance can be used, however the transmittable torque will decrease, see tables:

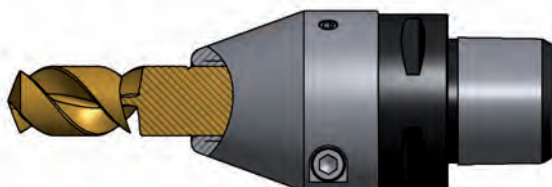

- at direct tool clamping

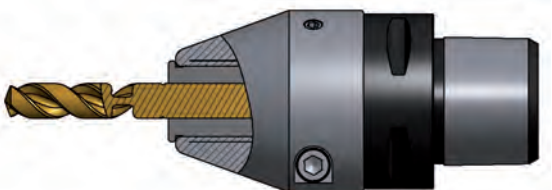

- at clamping with reducing sleeve

“By reducing the tool clamping length, an increase accessibility can be reached when machining. Below table indicates the reduction in torque capacity in such a case. For short time use only!”

Torque transmission capacity at different tool tolerances for:		HYDRO-GRIP / HYDRO-GRIP PENCIL							
Tool diameter in mm		6	8	10	12	16	20	25	32
Tol. h6 min.	Nm	12	27	35	60	165	260	480	820
Tol. h7 min.	Nm	7	18	14	30	105	175	350	630
Tol. Max (0)	Nm	22	40	70	125	270	425	710	1250
Tool diameter in inches		1/4"	5/16"	3/8"	1/2"	5/8"	3/4"	1"	1 1/4"
Tol. h6 min.	ft-lb	13	20	22	55	122	192	354	605
Tol. h7 min.	ft-lb	9	13	7	32	77	129	258	465
Tol. Max (0)	ft-lb	20	30	52	105	199	314	524	922

Torque transmission capacity at different tool tolerances for:		HYDRO-GRIP HD / ECOGRIP				
Tool diameter in mm		12	16	20	25	32
Tol. h6 min.	Nm	85	250	400	740	1325
Tol. h7 min.	Nm	50	190	330	630	1140
Tol. Max (0)	Nm	150	340	535	940	1670
Tool diameter in inches		1/2"	5/8"	3/4"	1"	1 1/4"
Tol. h6 min.	ft-lb	90	180	295	546	977
Tol. h7 min.	ft-lb	60	140	243	465	841
Tol. Max (0)	ft-lb	140	250	395	693	1232

Torque transmission capacity using reducing sleeves for:		HYDRO-GRIP / HYDRO-GRIP PENCIL			
		Tool with reducing sleeve in mm			
		12	20	25	32
Holder mm	Nm	Nm	Nm	Nm	Nm
12	60	-	-	-	-
20	95	260	-	-	-
25	140	235	480	-	-
32	190	350	520	820	-
		Tool with reducing sleeve in inches			
		1/2"	3/4"	1"	1 1/4"
Holder inch	ft-lb	ft-lb	ft-lb	ft-lb	ft-lb
1/2"	44	-	-	-	-
3/4"	70	192	-	-	-
1"	103	173	354	-	-
1 1/4"	140	258	384	605	-

Torque transmission capacity using reducing sleeves for:		HYDRO-GRIP HD / ECOGRIP			
		Tool with reducing sleeve in mm			
		12	20	25	32
Holder mm	Nm	Nm	Nm	Nm	Nm
12	-	-	-	-	-
20	170	400	-	-	-
25	260	470	740	-	-
32	340	640	950	1325	-
		Tool with reducing sleeve in inches			
		1/2"	3/4"	1"	1 1/4"
Holder inch	ft-lb	ft-lb	ft-lb	ft-lb	ft-lb
1/2"	-	-	-	-	-
3/4"	125	295	-	-	-
1"	192	347	546	-	-
1 1/4"	251	472	701	977	-

Transmittable torque

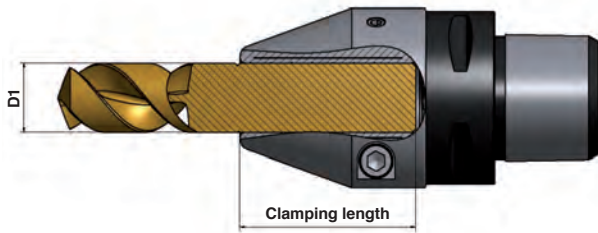

- at reduced clamping length

HYDRO-GRIP torque transmission capacity at different clamping lengths

Clamping length X diameter D1						
	1,0	1,5	2	2,5	3,0	Min. length*
Holder mm	Nm	Nm	Nm	Nm	Nm	mm
12	5	15	25	40	60	35
20	45	100	175	260	260	46.5
25	110	235	440	480	480	50.5
32	260	585	820	820	820	53.5

Clamping length X diameter D1						
	1,0	1,5	2	2,5	3,0	Min. length*
Holder inches	ft-lb	ft-lb	ft-lb	ft-lb	ft-lb	inch
1/2"	3.7	11	18	30	44	1.378
3/4"	33	74	129	192	192	1.831
1"	81	173	325	354	354	1.988
1 1/4"	192	431	605	605	605	2.106

Balancing:

All holders are dynamically balanced.
See corresponding product pages for details.

Runout:

All ETP holders are delivered with a high runout accuracy at time of delivery. The runout value is measured at $2.5 \times D1$.

See corresponding product pages for details.

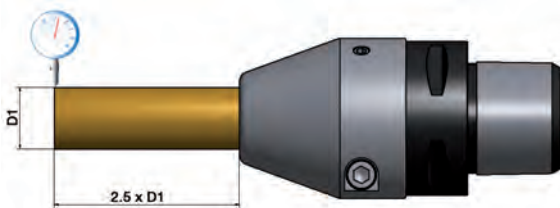

Recommended tightening torque:

- **HYDRO-GRIP** 6 Nm
- **HYDRO-GRIP HD** 10 Nm
- **ECOGRIP** 10 Nm

Always use a torque wrench for best chuck performance and repeatability.

- **Torque too high**
may cause screw damage.
- **Torque too low**
may cause tool vibration, tool movement, affects surface and tool accuracy, balancing.

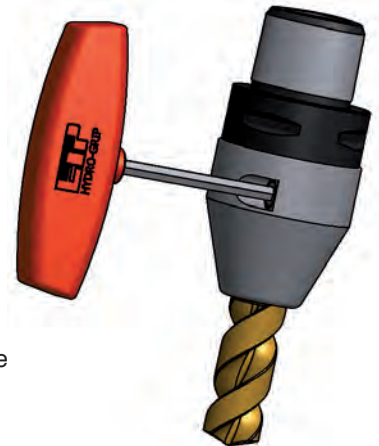

Handling:

ETP HYDRO-GRIP and ETP ECOGRIP are high precision toolholders and should be handled with care for optimal performance.

- Before inserting tool, check for damages on tool and holder.
- Tools should be of correct dimension and tolerance (h6 or h7), and cleaned.
- Do not use force to insert tool, it should easily slide in position.
- Mount the tool by tightening the pressure screw to the recommended tightening torque, marked on the holder. Use a fixed torque wrench.
- When stored lubricate the holder with a thin oil for corrosion resistance.
- Do not use HYDRO-GRIP/ECOGRIP at working temperatures above 85 degrees C / 185 degrees F. Do not use HYDRO-GRIP HD at working temperatures above 70 degrees C / 158 degrees F. (This may increase the pressure in the holder and influence it negatively).



Box 1120, SE-581 11 Linköping, Sweden
Tel. +46 (0)13 24 71 00
E-mail: info@etp.se, Internet: www.etp.se