

**Tough
and slender
design**



Benefits and features

- Quick and easy tool change
- High performance
- Slender design
- Excellent runout

ETP HYDRO-GRIP® G2 HSK 63F

HYDRO-GRIP type G2 is extremely user friendly which means quick and easy tool changes. It has a tough and slender design.

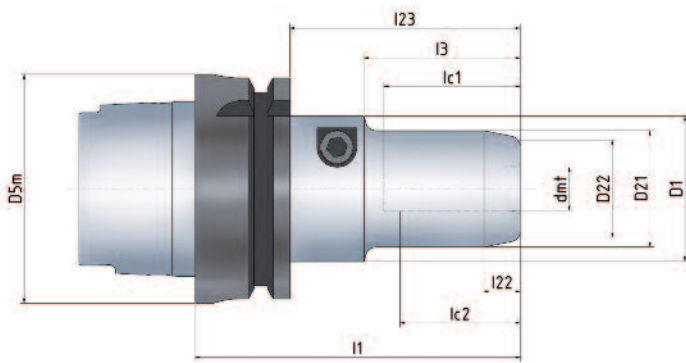

Technical Specification HSK form F

Dimensions, mm

HSK size	Part nb:	Item description	D_{5m}	d_{mf}	D_1	D_{21}	D_{22}	l_1	l_3	l_{22}	l_{23}	l_{c1}	l_{c2}
63	642680	HG G2-12/HSK63F	63	12	40	32	28	87	43	10	61	40	37
	642690	HG G2-16/HSK63F	63	16	40	38	34	87	43	10	61	40	37
	642700	HG G2-20/HSK63F	63	20	50	40	36	99	55	10	73	52	49
	639130	HG G2-25/HSK63F	63	25	50	45	41	103	59	10	77	56	53
	659400	HG G2-3/8"/HSK63F	63	0.375"	40	32	28	87	43	10	61	40	37
	642710	HG G2-1/2"/HSK63F	63	0.500"	40	32	34	87	43	10	61	40	37
	642730	HG G2-3/4"/HSK63F	63	0.750"	50	40	36	99	55	10	73	52	49
	639140	HG G2-1"/HSK63F	63	1.000"	50	45	41	103	59	10	77	56	53

The type G2 chuck is balanced to G2,5 at 25000 rpm. The runout is measured at 3xD and the max runout is 0,006 mm.